

ATAG

SERVING INDUSTRY SINCE 1947



EXTRUDED PROFILES
BUMPERS
FOAM



WWW.ATAG-EUROPE.COM

PAST, PRESENT, FUTURE

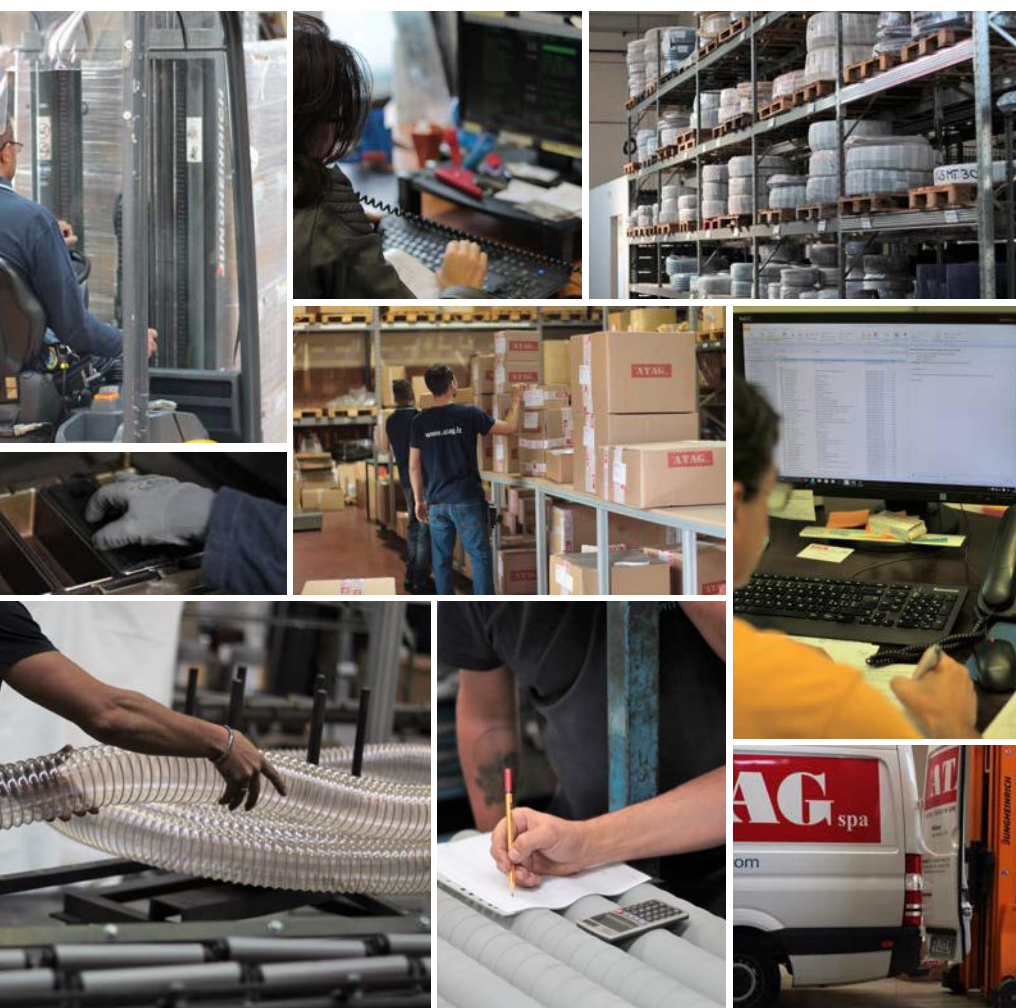

ATAG is serving industry since **1947** and is constantly growing.

The wide range of products, the three domestic locations plus one in Switzerland, the large warehouses, the extensive sales network, the increasingly stringent internal workings, the website in constant evolution and a service based on the qualified technical expertise offered by our sales department, are the reasons why our customers rely constantly on ATAG.

In recent years we have incorporated complementary companies, using their great competencies to improve our own skills. An efficient export department, our European resellers and long-standing customers, allow us to have a better knowledge of foreign markets and strengthen our presence beyond the Italian borders.

Collaborations and agreements with international prestige partners enable us to offer our country products and solutions that are already appreciated and well established in Europe, and to stimulate our research into improved solutions for the Italian industry.



EXTRUDED PROFILES, BUMPERS AND FOAM

The technical features of the elastomers mentioned in this catalogue are indicative and refer to the maximum values achievable. Also specific values are detailed that are achievable by the formulation of special compounds. Please do not hesitate to contact our Technical Department for further information and for assistance in choosing the most suitable compound for your application.



RUBBER MOULDINGS (see specific catalog)

We are able to produce moulded rubber and rubber/metal composite items to your specific designs, with the type of rubber being a function of the application and by means of the most appropriate method (compression, transfer and injection moulding).



FOAM

Our foam products comprise an immense range of materials that differ in density and porosity, chemical resistance derived from their base blend, as well as mechanical and thermal properties. The most common profiles of various foam materials are available ex-stock, **with many being self-adhesive on one side.**



EXTRUDED PROFILES

The **extruded profile designs** shown in this catalogue are only available from stock as **black EPDM rubber.**

We are able to supply non-standard **special profiles**, as per specific designs and in different types of rubber by utilising the most suitable extrusion methods.

Quantità minima producibile per sezioni regolari e speciali a disegno

- kg 10 ca. - Viton®
- kg 20 ca. - Peroxide and Platinum cured silicone
- kg 50 ca. - For all other types of rubber

Dimensional Tolerances

With reference to the table **UNI ISO 3302**, the class of tolerance to consider are as follows:

- **Class E2** – Regular profiles (round, rectangular, tubing and cuffs)
- **Class E3** – Profiles to design (profile for oblong, draw to a "point" or "U" and others) and for all foam profiles
- **Class E1** – To a specific design

Nominal Dimension		Class E1	Class E2	Class E3
<i>from mm</i>	<i>up to mm</i>	<i>± mm</i>	<i>± mm</i>	<i>± mm</i>
0	2,5	0,20	0,35	0,50
2,5	4,0	0,25	0,40	0,70
4,0	6,3	0,35	0,50	0,80
6,3	10	0,40	0,70	1,00
10	16	0,50	0,80	1,30
16	25	0,70	1,00	1,60
25	40	0,80	1,30	2,00
40	63	*	1,60	2,50
63	100	*	2,00	3,20

The data shown in the tables of this catalog are approximate: ATAG reserves the right to make appropriate changes of compounds, sizes and tolerances, without notice.

EXTRUDED PROFILES, BUMPERS AND FOAM



Extruded Profiles

Standard Industrial Rubber (SBR)

Caratteristiche	Uses
Colour: black, other colours on request	Trims, bumper, straps, floor coverings, etc.
Specific weight: Approx 1.5	
Hardness: 65 shore \pm 5	
Breaking load: good (up to 250 kg cm ²)	
Working temperature: +80 °C	
Low temperature resistance: good, down to -30 °C	
Resistance to atmospheric agents: meagre	
Resistance to abrasion, to laceration, to fatigue: excellent	
Chemical resistance in the presence of salts and bases, diluted acids: good	
Resistance to acetone and steam up to 100 °C: moderate	
Chemical resistance in the presence of ozone, hydrocarbons, lubricating oils, petrol: meagre	

PARA Natural Rubber (NR)

Characteristics	Uses
Colour: Avana	In laboratories for: high vacuum tubing, sealing rings of small and large dimensions, transportation of liquids and elastic bungs. In all applications where a high level of elasticity and abrasion resistance are required.
Specific weight: Approx 1.15	
Hardness: 45 shore \pm 5	
Breaking load: Optimal	
Elastic efficiency: excellent	
Low temperature resistance: optimal, down to -40 °C	
High temperature resistance: up to +70 °C	
Specific resistance ohm/cm ² : up to 10 ¹⁴	
Is light-sensitive and changes colour if exposed to light	
Abrasion resistance: exceptional	
Chemical resistance in the presence of dilute acids, salts, bases, alcohols and sea water: good	
Resistance to ozone, lubricating oils, mineral acids, petrol and solvents (excluding acetone): scarce	

Nitrile Rubber (NBR)

Characteristics	Uses
Colour: black, other colours available on request	Sealing rings, gaskets, inking and dragging rollers, bushings for electric motors, membranes, valves, pressure rooms etc.
Specific weight: approx 1.4.	
Hardness: 70 shore \pm 5	
Breaking load: moderate (up to 110 kg cm ²) - good (up to 210 kg cm ²) with optimal formulation	
Working temperature: very good +100 °C	
Low temperature resistance: average, down to -15 °C	
Specific Resistance ohm/cm ² : up to 10 ¹⁰ with optimal formulations	
Resistance to atmospheric agents: meagre, insufficient to ozone	
Abrasion Resistance: Good	
Impermeability to gas: from good to excellent	
Chemical resistance in the presence of gas, butane, methane, propane: excellent with optimal formulation	
Chemical resistance in the presence of hydrocarbons, lubricating oils, petrol: good	

Neoprene Rubber (CR)

Characteristics	Uses
Colours: black, other colours on request	Covering of electrical transformers, manufactured articles for the electrical industry, gaskets, supporting membranes for bridges and building, etc.
Specific weight: Approx. 1.4	
Hardness: 70 shore \pm 5	
Breaking load: moderate (up to 110 kg cm ²) - good (up to 230 kg cm ²) with optimal formulation	
Working temperature: +85 °C	
Low Temperature resistance: good, down to -25 °C	
Resistance to atmospheric agents: optimal	
Abrasion, laceration and fatigue resistance: optimal	
Chemical resistance in the presence of salts and bases, diluted acids, to oxidation, to ozone, to heat, to heat ageing: excellent	
Chemical resistance in the presence of aliphatic hydrocarbons, mineral lubricating oils, organics, impermeability to gas: good	
Self-extinguishing: on request UL94v1	



Extruded Profiles

Ethylene Propylene Rubber (EPDM)

Characteristics	Uses
Colour: black, other colours on request	Car windshield seals, profiled window seals, trim and plugs for buildings, expansion joints for bridges and viaducts, fenders and jetties, printing rollers, sub-aqua equipment etc.
Specific weight: 1.28	
Hardness: 70 shore \pm 5	
Breaking load: good (up to 180 kg cm ²)	
Working temperature: +130°C, intermittent +150 °C	
Low temperature resistance: good	
Specific resistance ohm/cm ² : up to 10 ¹²	
Resistance to atmospheric agents: optimal	
Resistance to abrasion, to laceration, to fatigue: optimal	
Chemical resistance in the presence of organic and inorganic acids, various esters, bases, salts and polar solvents: excellent	
Resistance to oxidation, ozone, heat and ageing: optimal	
Resistance to high concentration acids: good	
Resistance to petrol, lubricating oils, aromatic solvents and hydrocarbons: bad	

Silicone Rubber (VMQ) peroxide-cured

Characteristics	Uses
Colour: transparent, other colours on request	Seals for technical items where optimum resistance to heat and cold is required: quartz lamp reflectors, transformers, naphtha or gas burners, containers for solids and liquids. The Platinum-cured quality, on request, guarantees the fundamental requirements for food and pharmaceutical applications: conforms to FDA and BfR and is total exempt from PAH (Aromatic Polycyclic Hydrocarbons).
Specific weight: Approx. 1.2 (with colour also approx. 1.3)	
Hardness: 60 shore \pm 5	
Breaking load: fair (up to 90 kg cm ²)	
High temperature resistance: +180°C intermittent up to +250 °C	
Low temperature resistance: optimal, down to -60 °C	
Specific resistance ohm/cm ² : up to 10 ¹⁶	
Resistance to bad weather and ageing: optimal	
Permanent deformation: very low	
Light-sensitive and changes colour if exposed to light	
Chemical resistance to acids and bases: low	
For oils: good	
Resistance to petrol, to aromatic and chlorinated solvents: average	
Resistance to generic solvents: low	

Silicone Rubber METALDETECTABLE

Characteristics	Uses
Colour: Blue	Highly specific products for the food industry for the management of foreign bodies in foodstuff processes
Hardness: 70 Shore +-5.	
Elongation to failure : 300%	
Compression Set (25% for 24hrs at 150°C) : 17%	
Special characteristic: metaldetectable	
The above product contains only ingredients that are listed by the FDA under the 21 CFR number 177-2600	

Fluoroelastomer Rubber (FKM grade A)

Characteristics	Uses
Colour: black	Specific technical items for the mechanical, petro-chemical, chemicals, pharmaceutical, aeronautics, nuclear and rocketry industries. Indispensable in many applications where a specific resistance to chemical agents or solvents in presence of high temperatures is required.
Specific weight: Approx. 1.95.	
Hardness: 80 shore \pm 5 (other hardness on request from 65 to 95 shore)	
Breaking load: good (up to 140 kg cm ²)	
Working temperature: +200 °C, intermittent to +270°C (special version up to +290 °C on request)	
Low temperature resistance: fair, down to -15 °C (on request down to -25 °C)	
Permanent deformation: low	
Resistance to atmospheric agents and to heat: optimal	
Chemical resistance in the presence of trichloroethylene, chloroform, chlorobenzene, fuels, aliphatic and aromatic hydrocarbons, mineral acids, petrol, diluted and concentrated acids, lubricating oils, caustic soda, formaldehyde at 20 °C, perchloroethylene: excellent	
Resistance to contact with esters and ethers of low molecular weight, ketones, amines, hot anhydrous fluoric acid: low	

EXTRUDED PROFILES, BUMPERS AND FOAM



Extruded Profiles

Hoses dimensions: Compound quality SBR - NBR - CR - EPDM - VMQ - VITON®

Ø mm	SBR		NBR		CR		EPDM		VMQ PEROXIDE (available PLATINUM cured too)		VITON®	
	g/m	stock	g/m	stock	g/m	stock	g/m	stock	g/m	stock	g/m	stock
1,5x3	5	o	5	o	5	o	4	o	4	●	7	o
2x4	15	o	14	o	14	o	13	o	12	●	20	o
2x5	25	o	23	o	23	o	21	o	20	●	33	o
2x6	35	o	33	o	33	o	30	o	28	●	46	o
3x4	9	o	8	o	8	o	8	o	8	●	12	o
3x5	20	o	19	o	19	●	17	o	16	●	26	●
3x6	30	o	28	o	28	●	26	o	24	●	39	●
3x7	50	o	47	o	47	o	43	o	40	●	65	o
3x8	65	o	61	o	61	●	55	o	52	●	85	o
4x5	10	o	9	o	9	o	9	o	8	o	13	o
4x6	22	o	21	o	21	●	19	o	18	●	29	●
4x7	38	o	35	o	35	o	32	o	31	●	49	●
4x8	55	o	51	o	51	●	47	o	44	●	72	o
4x9	75	o	70	o	70	o	64	o	60	●	98	o
4x10	100	o	93	o	93	o	85	o	80	●	130	o
5x7	27	o	25	o	25	o	23	o	22	●	35	o
5x8	48	o	45	o	45	●	41	o	39	●	62	●
5x9	65	o	61	o	61	o	55	o	52	●	85	o
5x10	89	o	83	o	83	●	76	o	72	●	116	o
5x13	170	o	159	o	159	o	145	o	136	o	221	o
6x8	33	o	31	o	31	●	28	o	27	●	43	o
6x9	54	o	50	o	50	●	46	o	44	●	70	●
6x10	77	o	72	o	72	●	66	o	62	●	100	o
6x12	130	o	121	o	121	o	111	o	104	●	169	●
6x16	260	o	243	o	243	●	222	o	208	o	338	o
7x9	40	o	37	o	37	o	34	o	32	o	52	o
7x10	62	o	58	o	58	●	53	o	50	●	81	●
7x11	85	o	79	o	79	o	73	o	68	●	111	o
7x12	110	o	103	o	103	o	94	o	88	●	143	o
7x13	140	o	131	o	131	o	119	o	112	o	182	o
7x14	170	o	159	o	159	o	145	o	136	o	221	o
7x15	210	o	196	o	196	o	179	o	168	o	273	o
8x10	44	o	41	o	41	o	38	o	36	●	57	●
8x11	68	o	63	o	63	o	58	o	55	o	88	o
8x12	95	o	89	o	89	●	81	●	76	●	124	●
8x14	155	o	145	o	145	o	132	o	124	●	202	o
8x15	195	o	182	o	182	o	166	o	156	o	254	o
9x12	75	o	70	o	70	o	64	o	60	●	98	o
9x13	105	o	98	o	98	o	90	o	84	●	137	o
10x12	51	o	48	o	48	o	44	o	41	●	66	●
10x13	80	o	75	o	75	o	68	o	64	●	104	o
10x14	110	o	103	o	103	●	94	o	88	●	143	●
10x15	147	o	137	o	137	●	125	o	118	●	191	o
10x16	180	o	168	o	168	o	154	o	144	●	234	o
10x17	230	o	215	o	215	o	196	o	184	o	299	o
10x18	260	o	243	o	243	●	222	o	208	●	338	o
10x19	310	o	289	o	289	o	265	o	248	●	403	o
10x24	560	o	523	o	523	o	478	o	448	o	728	o
12x15	100	o	93	o	93	o	85	o	80	●	130	o
12x16	130	o	121	o	121	o	111	o	104	●	169	●
12x17	180	o	168	o	168	o	154	o	144	o	234	o
12x18	212	o	198	o	198	●	181	o	170	●	276	o
12x20	300	o	280	o	280	o	256	o	240	●	390	o
12x22	400	o	373	o	373	o	341	o	320	●	520	o
13x16	102	o	95	o	95	o	87	o	82	●	133	o
14x16	71	o	66	o	66	o	61	o	57	●	92	o

EXTRUDED PROFILES, BUMPERS AND FOAM



Extruded Profiles

Ø mm	SBR		NBR		CR		EPDM		VMQ PEROXIDE (available PLATINUM cured too)		VITON®	
	g/m	stock	g/m	stock	g/m	stock	g/m	stock	g/m	stock	g/m	stock
14x18	150	o	140	o	140	o	128	o	120	●	195	o
14x19	210	o	196	o	196	●	179	o	168	o	273	●
14x20	240	o	224	o	224	o	205	o	192	o	312	o
14x22	340	o	317	o	317	o	290	o	272	●	442	o
15x20	200	o	187	o	187	o	171	o	160	●	260	o
15x25	470	o	439	o	439	o	401	o	376	●	611	o
16x18	80	o	75	o	75	o	68	o	64	o	104	o
16x20	170	o	159	o	159	o	145	o	136	o	221	o
16x22	270	o	252	o	252	●	230	o	216	●	351	o
16x25	440	o	411	o	411	o	375	o	352	o	572	o
16x26	500	o	467	o	467	o	427	o	400	●	650	o
18x20	90	o	84	o	84	o	77	o	72	o	117	o
18x22	190	o	177	o	177	●	162	o	152	●	247	o
18x24	300	o	280	o	280	o	256	o	240	●	390	o
18x25	360	o	336	o	336	o	307	o	288	o	468	o
18x26	420	o	392	o	392	o	358	o	336	o	546	o
20x24	210	o	196	o	196	●	179	o	168	●	273	o
20x25	270	o	252	o	252	o	230	o	216	o	351	o
20x26	330	o	308	o	308	●	282	o	264	●	429	o
22x28	460	o	429	o	429	o	393	o	368	o	598	o
23x30	438	o	409	o	409	o	374	o	351	o	569	o
24x30	380	o	355	o	355	o	324	o	304	o	494	o
25x33	545	o	509	o	509	o	465	o	436	●	709	o
25x35	705	o	658	o	658	o	602	o	564	●	917	o
28x32	275	o	257	o	257	o	235	o	220	o	358	o
30x34	300	o	280	o	280	o	256	o	240	o	390	o
30x40	830	o	775	o	775	o	708	o	664	●	1079	o
35x40	450	o	420	o	420	o	384	o	360	●	585	o
40x46	610	o	569	o	569	o	521	o	488	●	793	o
40x48	810	o	756	o	756	o	691	o	648	●	1053	o
40x52	1300	o	1213	o	1213	o	1109	o	1040	●	1690	o

● = Usually on stock
o = On demand

EXTRUDED PROFILES, BUMPERS AND FOAM



Extruded Profiles

Various dimensions: hoses, profiles, lengths, bandaged hoses, tubulars Compound: Natural Rubber - EPDM

NATURAL RUBBER HOSES			NATURAL RUBBER PROFILES			SLEEVE* 1 m lengths						MANDREL BANDAGED NATURAL RUBBER HOSES		
Ø mm	g/m	stock	mm	g/m	stock	NATURAL RUBBER			EPDM			Ø mm	roll m	stock
						mm	g/m	stock	mm	g/m	stock			
2x11	105	o	3x3	10	●	8x25	506	●	5x25	539	●	5x16	40	o
3x5	14	●	3x10	35	●	8x30	754	●	6x15	169	●	6x18	40	o
3x6	24	●	3x12	41	●	10x20	271	●	6x18	258	●	7x13	40	o
3x10	82	●	3x15	52	o	10x25	474	●	8x15	144	●	7x15	40	o
4x8	43	●	3x20	69	●	10x30	722	●	8x18	233	●	7x18	40	o
4x10	76	●	3x25	86	o	10x35	1016	●	8x20	302	●	8x20	40	●
4x12	115	●	3x30	103	o	10x40	1354	●	8x25	503	●	10x20	40	●
5x8	35	o	3x35	121	o	12x20	231	●	10x18	201	●	10x25	40	●
5x10	68	o	3x40	138	●	12x25	434	●	10x20	269	●	12x20	40	●
5x12	107	●	3x45	153	o	12x30	682	●	10x25	471	●	15x25	40	●
5x15	180	o	3x50	172	●	12x35	976	●	10x30	718	●	15x35	40	●
5x16	208	●	4x4	18	o	12x40	1314	●	10x35	1009	●	20x30	40	●
5x18	270	o	4x10	46	●	12x45	1698	●	10x40	1346	●	20x40	40	●
6x9	40	o	4x12	55	●	15x25	361	●	12x20	229	●	25x35	40	●
6x10	58	o	4x15	69	o	15x30	609	●	12x22	304	●	25x45	40	●
6x12	97	o	4x20	92	●	15x35	903	●	12x25	432	●	25x50	40	●
6x15	170	●	4x25	115	●	15x40	1241	●	12x30	678	●	28x31	40	o
6x16	200	o	4x30	138	●	15x45	1625	●	12x35	970	●	30x40	40	●
6x17	230	●	4x35	161	o	15x50	2054	●	12x40	1307	●	30x45	40	●
6x18	260	o	4x40	184	●	15x60	3047	●	13x45	1665	●	30x50	40	●
6x20	330	●	4x50	230	o	15x65	3611	●	15x20	156	●	30x58	40	o
7x10	45	o	5x5	29	●	15x80	5574	●	15x25	358	●	30x78	40	o
7x13	110	o	5x7	40	●	18x30	520	●	15x30	605	●	35x45	40	●
7x15	160	o	5x10	57	●	18x35	813	●	15x35	897	●	35x48	40	●
7x18	250	●	5x12	69	●	18x40	1152	●	15x40	1233	●	36x41	40	o
7x20	315	●	5x15	86	●	18x50	1964	●	15x45	1615	●	40x50	40	●
7x25	520	●	5x20	115	●	18x60	2957	●	15x50	2041	●	40x54	40	●
7x30	770	●	5x25	144	●	20x30	451	●	15x60	3028	●	40x60	40	●
8x12	72	o	5x30	172	●	20x35	745	●	18x25	270	●	40x65	40	●
8x15	145	●	5x35	201	o	20x40	1083	●	18x30	517	●	40x80	40	●
8x18	235	●	5x40	230	o	20x45	1467	●	18x35	808	●	45x55	40	●
8x20	303	●	5x50	287	●	20x50	1896	●	18x40	1145	●	45x49	40	o
8x22	380	o	6x6	41	●	20x60	2888	●	18x50	1952	●	48x60	40	o
8x30	755	●	7x10	80	●	20x70	4062	●	18x60	2939	●	50x60	40	●
9x13	80	o	8x8	74	●	20x80	5416	●	20x30	449	●	50x63	40	o
9x24	445	●	8x10	92	●	25x40	880	●	20x35	741	●	50x65	40	●
10x14	85	o	8x15	138	●	25x45	1264	●	20x40	1076	●	50x70	40	●
10x15	112	●	8x20	184	o	25x50	1692	●	20x45	1458	●	60x65	40	●
10x16	140	o	8x25	230	●	25x55	2166	●	20x50	1883	●	60x70	40	●
10x18	202	●	8x30	276	●	25x60	2686	●	20x60	2871	●	60x75	40	●
10x20	270	●	8x35	322	●	25x70	3859	●	20x70	4037	●	60x80	40	●
10x24	430	o	8x40	368	●	25x75	4514	●	20x80	5382	●	65x75	40	●
10x25	474	●	8x45	414	o	25x80	5213	●	20x90	6907	●	70x80	40	●
10x30	722	o	8x50	460	o	25x100	8463	●	25x30	247	●	70x85	40	●
12x15	73	●	10x10	115	●	28x40	736	●	25x35	539	●	75x85	40	●
12x16	101	●	10x12	138	●	30x40	632	●	25x40	875	●	80x90	40	●
12x17	131	●	10x15	172	●	30x45	1016	●	25x45	1256	●	80x95	40	●
12x18	162	●	10x20	230	●	30x50	1444	●	25x50	1682	●	90x96	40	o
12x20	230	●	10x25	287	●	30x57	2120	●	25x60	2669	●	90x105	20/40	●
12x22	306	o	10x30	345	●	30x60	2437	●	25x70	3835	●	90x110	20/40	●
12x25	435	●	10x35	402	o	30x70	3611	●	25x80	5181	●	100x104	20/40	o
12x30	682	o	10x40	460	●	30x80	4965	●	25x100	8411	●	100x106	20/40	o
12x35	975	o	10x50	575	●	30x90	6500	●	30x40	628	●	100x115	20/40	●
13x16	78	●	12x12	166	●	30x100	8215	●	30x45	1009	●	100x120	20/40	●
13x19	173	●	12x15	207	●	40x50	812	●	30x50	1435	●	110x125	20/40	●

EXTRUDED PROFILES, BUMPERS AND FOAM



Extruded Profiles

Squared and rectangular section: Compound quality SBR - NBR - CR - EPDM - VMQ - VITON®

Section mm	SBR		NBR		CR		EPDM		VMQ PEROXIDE (available PLATINUM cured too)		VITON®	
	g/m	stock	g/m	stock	g/m	stock	g/m	stock	g/m	stock	g/m	stock
2x40	120	o	112	●	112	o	102	o	96	o	156	o
3x3	13	o	12	o	12	o	11	o	10	●	17	o
3x10	46	o	43	●	43	o	39	o	37	●	59	o
3x12	53	o	50	●	50	o	46	o	43	●	70	o
3x15	68	o	63	o	63	o	58	o	54	●	88	o
3x20	90	o	84	o	84	o	77	o	72	●	117	o
3x25	112	o	105	●	105	o	96	o	90	●	146	o
3x30	134	o	125	●	125	o	115	o	107	●	175	o
3x35	158	o	147	●	147	o	135	o	126	●	205	o
3x40	180	o	168	●	168	o	154	o	144	●	234	o
3x45	202	o	189	●	189	o	173	o	162	●	263	o
3x50	224	o	209	●	209	o	191	o	179	●	292	o
3x60	270	o	252	●	252	o	230	o	216	o	351	o
4x4	23	o	22	●	22	o	20	o	19	●	31	o
4x7	42	o	39	o	39	o	36	o	33	o	54	o
4x10	60	o	56	o	56	o	51	o	48	●	78	o
4x12	72	o	67	●	67	o	61	o	57	●	93	o
4x15	90	o	84	●	84	o	77	o	72	●	117	o
4x20	120	o	112	●	112	o	102	o	96	o	156	o
4x25	150	o	140	●	140	o	128	o	120	o	195	o
4x30	180	o	168	●	168	o	154	o	144	o	234	o
4x35	210	o	196	●	196	o	179	o	168	o	273	o
4x40	240	o	224	●	224	o	205	o	192	o	312	o
4x45	270	o	252	●	252	o	230	o	216	o	351	o
4x50	300	o	280	●	280	o	256	o	240	o	390	o
4x60	360	o	336	●	336	o	307	o	288	o	468	o
5x5	38	o	35	●	35	o	32	o	30	●	49	o
5x7	52	o	49	●	49	o	45	o	42	●	68	o
5x10	74	o	69	●	69	o	63	o	59	●	97	o
5x12	90	o	84	o	84	o	77	o	72	●	117	o
5x15	112	o	105	●	105	o	96	o	90	●	146	o
5x20	150	o	140	o	140	o	128	o	120	●	195	o
5x25	188	o	175	●	175	o	160	o	150	●	244	o
5x30	224	o	209	●	209	o	191	o	179	●	292	o
5x35	262	o	245	●	245	o	224	o	210	o	341	o
5x40	300	o	280	●	280	o	256	o	240	●	390	o
5x45	338	o	315	●	315	o	288	o	270	o	439	o
5x50	374	o	349	●	349	o	319	o	299	●	487	o
5x60	450	o	420	o	420	o	384	o	360	o	585	o
6x6	53	o	50	●	50	o	46	o	43	●	70	o
7x10	104	o	97	o	97	o	89	o	83	●	136	o
7x15	158	o	147	●	147	o	135	o	126	o	205	o
7x20	210	o	196	●	196	o	179	o	168	o	273	o
7x25	262	o	245	●	245	o	224	o	210	o	341	o
8x8	97	o	90	●	90	o	82	o	77	●	125	o
8x12	143	o	134	o	134	o	122	o	115	o	187	o
8x15	180	o	168	●	168	o	154	o	144	●	234	o
8x20	240	o	224	●	224	o	205	o	192	●	312	o
8x25	300	o	280	●	280	o	256	o	240	●	390	o
8x30	360	o	336	o	336	o	307	o	288	●	468	o
8x35	420	o	392	●	392	o	358	o	336	o	546	o
8x40	480	o	448	●	448	o	410	o	384	●	624	o
8x45	540	o	504	●	504	o	461	o	432	o	702	o
8x50	600	o	560	o	560	o	512	o	480	●	780	o
8x60	720	o	672	o	672	o	614	o	576	o	936	o
10x10	150	o	140	●	140	o	128	o	120	●	195	o

EXTRUDED PROFILES, BUMPERS AND FOAM



Extruded Profiles

Section mm	SBR		NBR		CR		EPDM		VMQ PEROXIDE (available PLATINUM cured too)		VITON®	
	g/m	stock	g/m	stock	g/m	stock	g/m	stock	g/m	stock	g/m	stock
10x12	180	o	168	●	168	o	154	o	144	●	234	o
10x15	224	o	209	●	209	o	191	o	179	●	292	o
10x20	300	o	280	●	280	o	256	o	240	●	390	o
10x25	374	o	349	●	349	o	319	o	299	●	487	o
10x30	450	o	420	●	420	o	384	o	360	●	585	o
10x35	524	o	489	●	489	o	447	o	419	o	682	o
10x40	600	o	560	●	560	o	512	o	480	●	780	o
10x45	674	o	629	o	629	o	575	o	539	o	877	o
10x50	750	o	700	●	700	o	640	o	600	●	975	o
10x60	900	o	840	o	840	o	768	o	720	o	1170	o
10x100	1500	o	1400	o	1400	o	1280	o	1200	o	1950	o
12x12	217	o	202	●	202	o	185	o	173	●	281	o
12x15	270	o	252	o	252	o	230	o	216	●	351	o
12x20	360	o	336	●	336	o	307	o	288	●	468	o
12x25	450	o	420	●	420	o	384	o	360	●	585	o
12x30	540	o	504	●	504	o	461	o	432	o	702	o
12x35	630	o	588	●	588	o	538	o	504	o	819	o
12x40	720	o	672	o	672	o	614	o	576	o	936	o
12x45	810	o	756	o	756	o	691	o	648	o	1053	o
12x50	900	o	840	●	840	o	768	o	720	o	1170	o
15x15	338	o	315	●	315	o	288	o	270	●	439	o
15x20	450	o	420	●	420	o	384	o	360	●	585	o
15x25	562	o	525	●	525	o	480	o	450	●	731	o
15x30	674	o	629	o	629	o	575	o	539	●	877	o
15x35	788	o	735	●	735	o	672	o	630	o	1024	o
15x40	900	o	840	●	840	o	768	o	720	o	1170	o
15x45	1012	o	945	●	945	o	864	o	810	o	1316	o
15x50	1124	o	1049	●	1049	o	959	o	899	o	1462	o
15x60	1350	o	1260	●	1260	o	1152	o	1080	o	1755	o
20x20	600	o	560	●	560	o	512	o	480	●	780	o
20x25	750	o	700	●	700	o	640	o	600	●	975	o
20x30	900	o	840	●	840	o	768	o	720	●	1170	o
20x35	1050	o	980	●	980	o	896	o	840	o	1365	o
20x40	1200	o	1120	o	1120	o	1024	o	960	●	1560	o
20x45	1350	o	1260	●	1260	o	1152	o	1080	o	1755	o
20x50	1500	o	1400	o	1400	o	1280	o	1200	o	1950	o
20x60	1800	o	1680	o	1680	o	1536	o	1440	o	2340	o
25x25	938	o	875	●	875	o	800	o	750	●	1219	o
25x30	1124	o	1049	●	1049	o	959	o	899	●	1462	o
25x35	1312	o	1225	●	1225	o	1120	o	1050	o	1706	o
25x40	1500	o	1400	o	1400	o	1280	o	1200	o	1950	o
25x50	1874	o	1749	●	1749	o	1599	o	1499	o	2437	o
25x60	2250	o	2100	o	2100	o	1920	o	1800	o	2925	o
30x30	1350	o	1260	o	1260	o	1152	o	1080	●	1755	o
30x40	1800	o	1680	●	1680	o	1536	o	1440	●	2340	o
30x50	2250	o	2100	●	2100	o	1920	o	1800	o	2925	o
30x60	2700	o	2520	●	2520	o	2304	o	2160	o	3510	o
35x35	1838	o	1715	o	1715	o	1568	o	1470	o	2389	o
40x40	2400	o	2240	●	2240	o	2048	o	1920	●	3120	o
45x45	3038	o	2835	o	2835	o	2592	o	2430	o	3949	o
50x50	3750	o	3500	●	3500	o	3200	o	3000	o	4875	o
60x60	5400	o	5040	o	5040	o	4608	o	4320	o	7020	o
80x80	9600	o	8960	o	8960	o	8192	o	7680	o	12480	o
100x80	12000	o	11200	o	11200	o	10240	o	9600	o	15600	o
100x100	15000	o	14000	o	14000	o	12800	o	12000	o	19500	o

EXTRUDED PROFILES, BUMPERS AND FOAM



Extruded Profiles

Round section: Roll - Bar Compound quality SBR - NBR - CR - EPDM - VMQ - VITON®

Ø mm	SBR		NR		NBR		CR		EPDM		VMQ PEROXIDE (available PLATINUM cured too)		VITON®	
	g/m	stock	g/m	stock	g/m	stock	g/m	stock	g/m	stock	g/m	stock	g/m	stock
1,78	4	o	3	o	4	●	4	o	3	o	3	o	5	o
2	5	o	3,5	o	4	●	4	o	4	o	4	●	6	o
2,62	8	o	6	o	7	●	7	o	7	o	6	o	10	●
3	10	o	8	●	10	●	10	o	9	o	8	●	14	●
3,2	12	o	9	o	11	o	11	o	10	o	9	o	15	o
3,53	14	o	11	o	13	●	13	o	12	o	11	o	19	●
4	19	o	14,5	o	18	●	18	o	16	o	15	●	25	●
4,5	23	o	18	o	22	●	22	o	20	o	19	o	31	o
5	29	o	22,5	●	27	●	27	o	25	●	23	●	38	●
5,34	34	o	26	o	32	●	32	o	29	o	27	o	44	●
6	42	o	32,5	●	40	●	40	o	36	●	34	●	55	o
6,35	48	o	36,5	o	44	●	44	o	41	o	38	o	62	●
7	57	o	44	o	54	●	54	o	49	●	46	●	75	o
8	76	o	58	●	71	●	71	o	65	●	61	●	98	●
9	95	o	73	o	89	●	89	o	81	●	76	●	124	o
10	117	o	90	●	110	●	110	o	100	●	94	●	153	●
11	142	o	109	o	133	●	133	o	121	●	114	●	185	o
12	170	o	130	●	158	●	158	o	145	●	136	●	220	●
13	199	o	152,5	o	186	●	186	o	170	●	159	●	259	●
14	231	o	177	●	215	●	215	o	197	●	185	●	300	o
15	265	o	203	●	247	●	247	o	226	●	212	●	344	●
15*	265	o	203	o	247	o	247	o	226	●	212	o	344	●
16	301	o	231	o	281	●	281	o	257	●	241	●	392	●
18	382	o	292,5	o	356	●	356	o	326	●	305	●	496	●
20	471	o	361	●	439	●	439	o	402	●	377	●	612	o
20*	471	o	361	●	439	●	439	o	402	●	377	o	612	o
22	570	o	437	o	532	●	532	o	486	●	456	●	741	o
22*	570	o	437	o	532	●	532	o	486	●	456	o	741	o
25	736	o	564	●	687	●	687	o	628	●	589	●	956	o
25*	736	o	564	●	687	●	687	o	628	●	589	o	956	o
30	1059	o	812	●	989	o	989	o	904	●	847	●	1377	o
30*	1059	o	812	o	989	●	989	o	904	●	847	o	1377	o
35	1443	o	1106	●	1346	●	1346	o	1231	●	1154	●	1875	o
35*	1443	o	1106	●	1346	●	1346	o	1231	●	1154	o	1875	o
40	1885	o	1445	●	1759	●	1759	o	1608	●	1508	●	2450	o
40*	1885	o	1445	●	1759	●	1759	o	1608	●	1508	o	2450	o
45	2387	o	1830	●	2228	●	2228	o	2037	●	1910	o	3103	o
45*	2387	o	1830	●	2228	●	2228	o	2037	●	1910	o	3103	o
50	2944	o	2257	●	2748	●	2748	o	2512	●	2355	o	3827	o
50*	2944	o	2257	●	2748	●	2748	o	2512	●	2355	o	3827	o
55	3562	o	2731	●	3325	●	3325	o	3040	●	2850	o	4631	o
55*	3562	o	2731	●	3325	●	3325	o	3040	●	2850	o	4631	o
60*	4239	o	3250	●	3957	o	3957	o	3617	●	3391	o	5511	o
65*	4976	o	3815	●	4644	o	4644	o	4246	●	3981	o	6469	o
70*	5769	o	4423	●	5385	●	5385	o	4923	●	4615	o	7500	o
75*	6622	o	5077	●	6181	●	6181	o	5651	●	5298	o	8609	o
80*	7535	o	5777	●	7033	●	7033	o	6430	●	6028	o	9796	o
90*	9537	o	7312	●	8902	●	8902	o	8139	●	7630	o	12399	o
95*	10627	o	8147	o	9918	●	9918	o	9068	●	8501	o	13814	o
100*	11778	o	9030	●	10993	●	10993	o	10051	●	9423	o	15312	o
110*	14255	o	10930	o	13305	●	13305	o	12165	●	11403	o	18530	o
115*	15600	o	12000	o	14610	●	14610	o	13300	●	12500	o	20300	o
120*	17000	o	13050	o	15890	●	15890	o	14530	●	13620	o	22140	o

● = Normalmente a scorta;

o = Su richiesta;

* = Larghezza 1 metro.



Extruded Profiles

Here are section details of the **profile extrusions** that we have in stock or that we can supply quickly as we already have the tooling.

They are just a small part of what we can achieve with our **extrusion technology**. Any shape can be manufactured by constructing the appropriate design for the die. Our sales department is able to assist you with this task.

All profiles shown in the catalogue are made of **EPDM rubber** (see compound properties on pages 4 & 5), but we also extrude other types of rubber.

We can also extrude **silicone profiles** which are produced **in clean room** environments for **pharmaceutical and medical applications**. Each standard profile is extruded with tolerances according to DIN 7715, UNI ISO 3302 Cl.E3, but on request, for certain profiles, it is possible to reduce the tolerance specification.

Specifically for the **food industry**, but also increasingly in the **pharmaceutical industry**, the use of **metal detectable** plastics and rubbers is today an important criteria.

The management of **foreign bodies** in foodstuff processes is a critical factor, especially in relation to international quality standards.

We are able to extrude any packing or seal, of either regular or irregular shape or to customer specific designs, using fully compliant and **metal detectable FDA** blends.

The norms indicated are the more restricted class E1, applicable to extrusions, however, only up to certain dimensions (see reference standard).

Our production uses **continuous vulcanization technology**.

This allows the manufacture of considerable length profiles and enables dimensional stability to be obtained immediately after extrusion, thereby avoiding unwanted deformation due to the use of pans for positioning the raw extrusions into ovens.

If, however, due to the size and shape of a profile it is more expedient to cure at low temperatures over a long duration, we are able to offer the solution of **autoclave vulcanisation**.

The characteristics of this material allow industry to have immediate control on the end product, thereby hastening quality control processes and minimising the potential for economic loss.

EXTRUDED PROFILES, BUMPERS AND FOAM



Profiles

Rubber profiles: Quality black EPDM (available on request other compounds kinds)



01 126 g/m



02 180 g/m



03 82 g/m



04 106 g/m



05 104 g/m

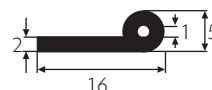

06 60 g/m



07 154 g/m



08 104 g/m

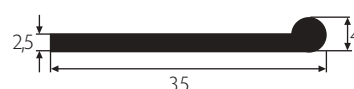

09 120 g/m



10 134 g/m



11 110 g/m



12 124 g/m



13 204 g/m



14 102 g/m



15 106 g/m



16 150 g/m



17 140 g/m



18 158 g/m



19 106 g/m



20 170 g/m



21 136 g/m

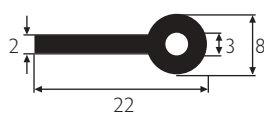

22 90 g/m



23 160 g/m

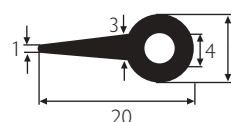

24 In esaurimento

EXTRUDED PROFILES, BUMPERS AND FOAM



Profiles

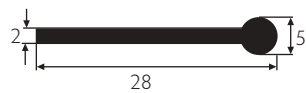

25 84 g/m



26 116 g/m



27 50 g/m

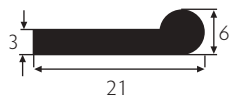

28 102 g/m



29 112 g/m

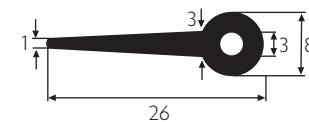

30 124 g/m



31 160 g/m

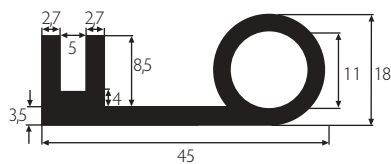

32 362 g/m



33 100 g/m

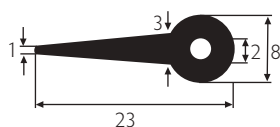

34 120 g/m



35 130 g/m



36 100 g/m



37 70 g/m



38 140 g/m



39 180 g/m



40 136 g/m



41 124 g/m

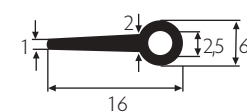

42 56 g/m



43 92 g/m



44 142 g/m



45 114 g/m

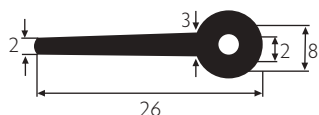

46 140 g/m

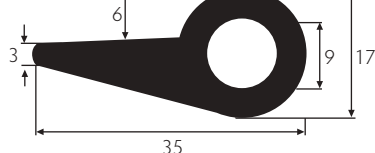

47 352 g/m



48 124 g/m

EXTRUDED PROFILES, BUMPERS AND FOAM



Profiles

Rubber profiles: Quality black EPDM (available on request other compounds kinds)

<p>49 398 g/m</p>	<p>100 36 g/m</p>
<p>101 34 g/m</p>	<p>102 82 g/m</p>
<p>104 56 g/m</p>	<p>105 36 g/m</p>
<p>107 74 g/m</p>	<p>108 36 g/m</p>
<p>110 82 g/m</p>	<p>111 106 g/m</p>
<p>113 70 g/m</p>	<p>114 72 g/m</p>
<p>116 108 g/m</p>	<p>117 116 g/m</p>
<p>119 94 g/m</p>	<p>120 20 g/m</p>
<p>103 44 g/m</p>	<p>106 88 g/m</p>
<p>109 72 g/m</p>	<p>112 64 g/m</p>
<p>115 70 g/m</p>	<p>118 100 g/m</p>
<p>121 94 g/m</p>	

EXTRUDED PROFILES, BUMPERS AND FOAM



Profiles

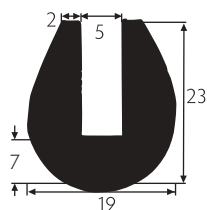

122 388 g/m

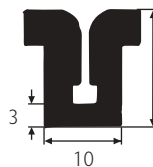

123 186 g/m



124 24 g/m

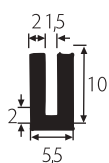

125 74 g/m

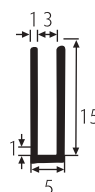

126 56 g/m

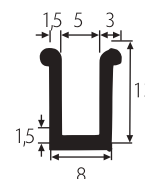

127 88 g/m

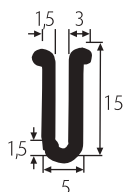

128 86 g/m

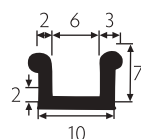

129 54 g/m

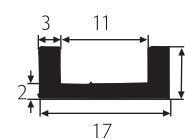

130 96 g/m

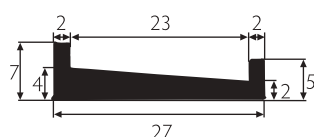

131 144 g/m

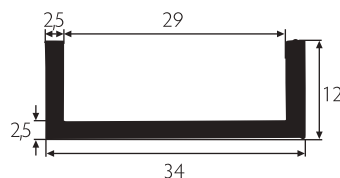

132 186 g/m

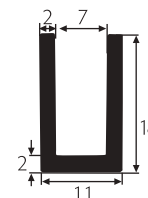

134 152 g/m

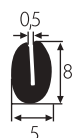

135 36 g/m

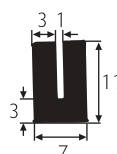

136 94 g/m

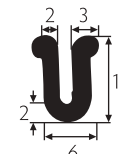

137 64 g/m

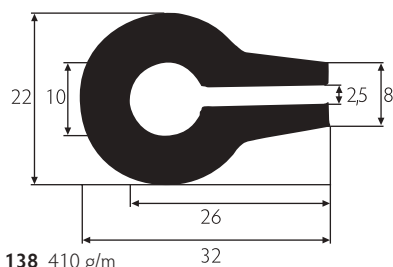

138 410 g/m

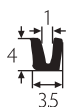

139 25 g/m



140 76 g/m

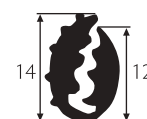

141 122 g/m

EXTRUDED PROFILES, BUMPERS AND FOAM



Profiles

Rubber profiles: Quality black EPDM (available on request other compounds kinds)

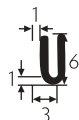

142 26 g/m

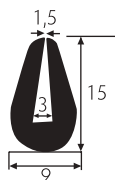

143 130 g/m

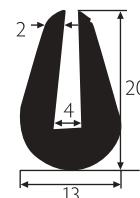

144 200 g/m

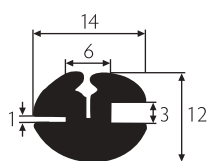

198 134 g/m (con spina 260P)

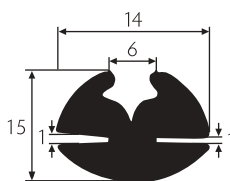

200 246 g/m (con spina 260)

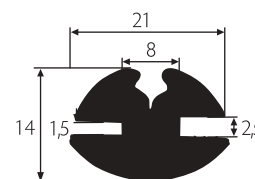

201 290 g/m (con spina 260P)

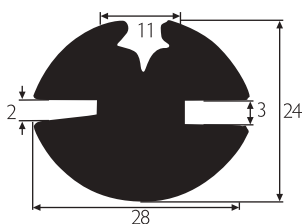

202 592 g/m (con spine: 260, 205 e 206)

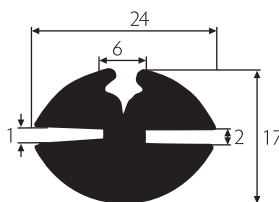

203 358 g/m (con spina 260)

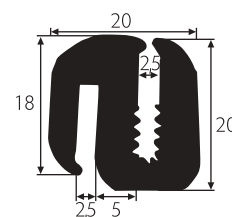

204 364 g/m

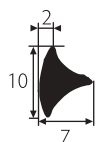

205 50 g/m

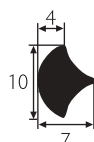

206 80 g/m

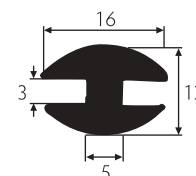

208 200 g/m

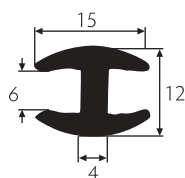

209 145 g/m

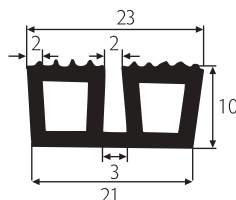

210 184 g/m

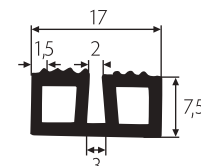

211 112 g/m

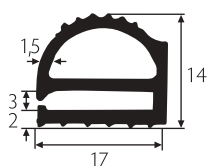

212 132 g/m

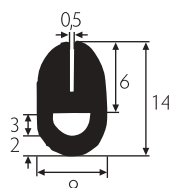

213 125 g/m

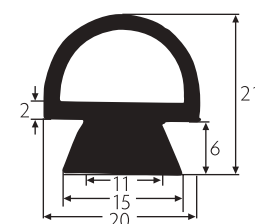

214 276 g/m

EXTRUDED PROFILES, BUMPERS AND FOAM



Profiles

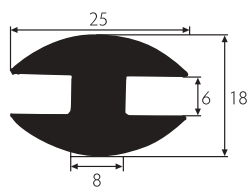

215 350 g/m

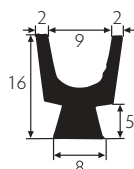

216 131 g/m

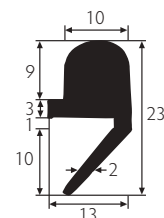

218 273 g/m

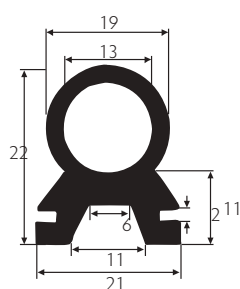

219 375 g/m

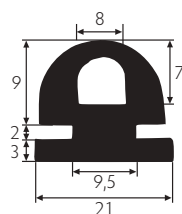

220 356 g/m

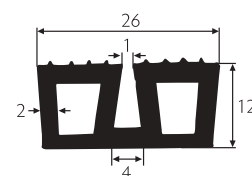

221 224 g/m

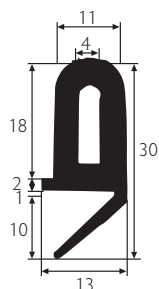

222 316 g/m

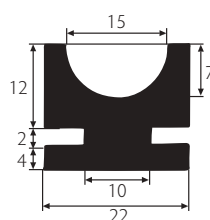

223 500 g/m

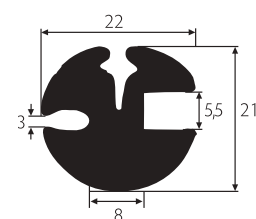

225 360 g/m (con spina 260)

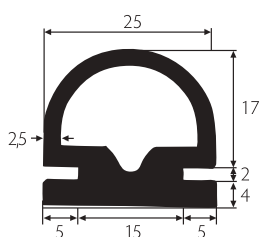

226 334 g/m

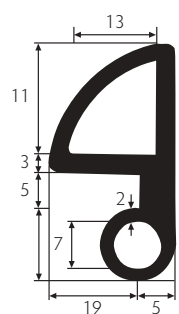

227 438 g/m

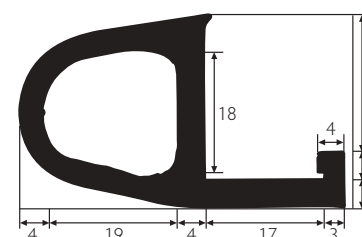

228 468 g/m

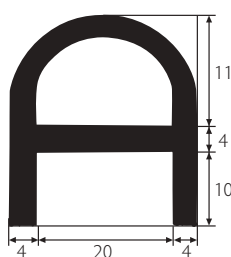

229 410 g/m

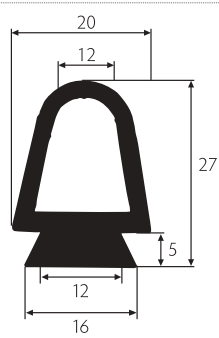

230 425 g/m

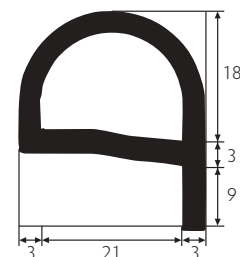

231 375 g/m

EXTRUDED PROFILES, BUMPERS AND FOAM



Profiles

Rubber profiles: Quality black EPDM (available on request other compounds kinds)

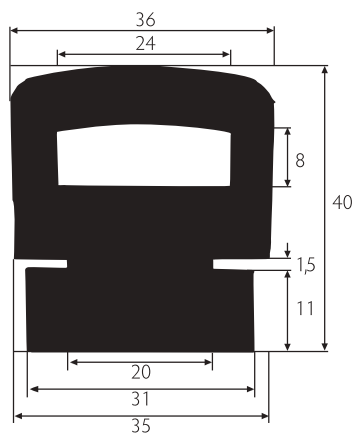

232 1750 g/m

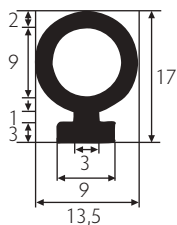

234 0,146 g/m

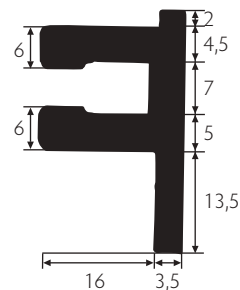

236 500 g/m

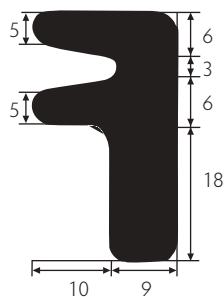

237 521 g/m

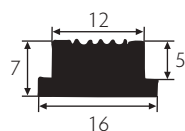

239 125 g/m

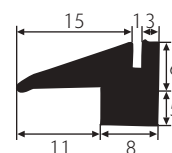

240 133 g/m

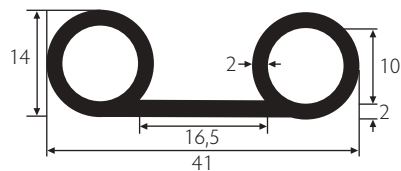

242 313 g/m

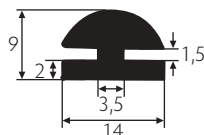

244 133 g/m

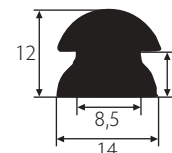

245 188 g/m

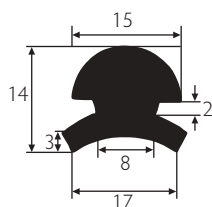

246 263 g/m

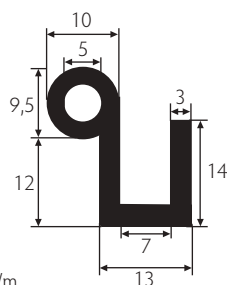

247 230 g/m

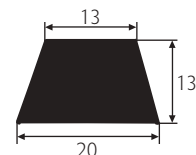

250 275 g/m

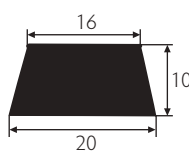

251 313 g/m

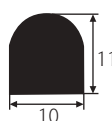

252 150 g/m

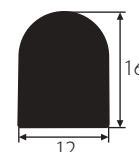

253 275 g/m

EXTRUDED PROFILES, BUMPERS AND FOAM



Profiles

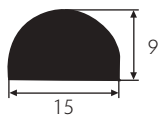

254 193 g/m

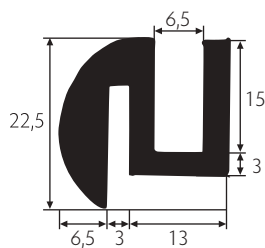

257 375 g/m

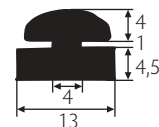

258 163 g/m

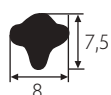

260 63 g/m



260/P 40 g/m



261 45 g/m

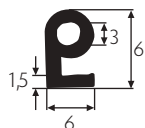

265 56 g/m

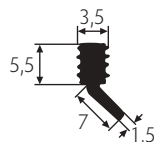

272 50 g/m

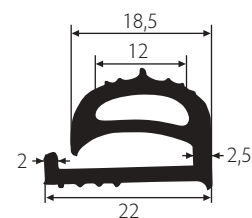

273 172 g/m

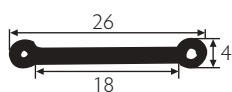

279 525 g/m

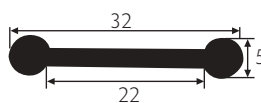

280 103 g/m

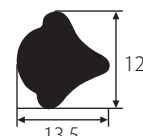

281 195 g/m

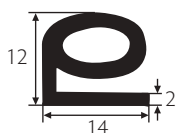

282 138 g/m

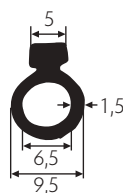

285 78 g/m

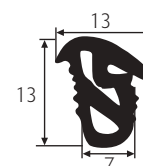

286 102 g/m

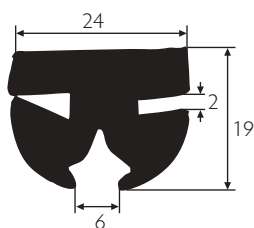

288 563 g/m

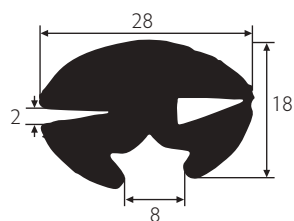

292 563 g/m (con spina 260)

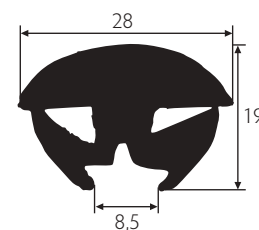

293 402 g/m (con spina 205)

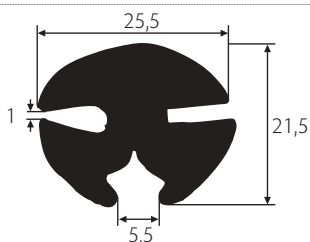

296 563 g/m (con spina 260)

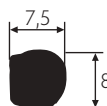

297 81 g/m



Profiles

D-Shaped Bumpers and cylindrical bumpers in Ethylene Propylene: EPDM

Light, robust and easy to mount; these **D-shaped bumpers** have a wide range of uses: for **nautical applications** such as fenders for boats, paths and jetties; for **industry and commerce** such as the protection of masonry, prefabricated structures, scaffolding and machinery when moving indoors; for the protection of loading bays and docks from the rear of trucks. The **Cylindrical Bumpers** for marine use have the advantage of easier installation thereby reducing the time required to fit them.

STRUCTURE

Mixture of black rubber particularly designed for resistance to: hitting, abrasion, laceration, ageing, atmospheric agents and sea water.

STANDARD LENGTH

For **D-SHAPED**, the section 40 x 22: 25 metre (max), for all the other sections: 4 metre (max)
For **CYLINDRICAL**, the length is on request up to 1 meter

SPECIAL VERSIONS

On request we can supply bumpers to your specific design and in non-standard rubbers.

FIXING

To mount types ① ② and ③

Drill the profile at point A with a hole diameter slightly greater than the head of the bolt, to allow the insertion of an allen key, or if using an hexagonal head (type brugola) the diameter of the hole will be that of the head of the bolt; then drill the base of the profile at point B with a hole diameter the same size as the fixing.

To mount type ④

Drill a hole passing through the base of the profile at point C with the \varnothing the same as that of the fixing.

To best avoid damaging the bumper when mounting it is advisable to use washers and to tighten bolts only until the point where the rubber starts to deform, ensuring that the bolt thread is not visible. In case of additional gluing clean the bumper perfectly and degrease the mounting surface; if necessary lightly sand the bumper's mounting surface.

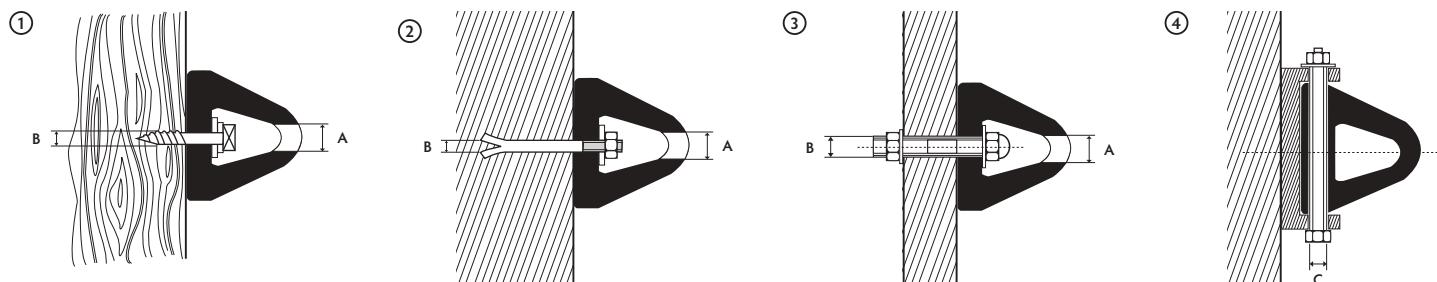

ASSEMBLY (relative to cylindrical model)

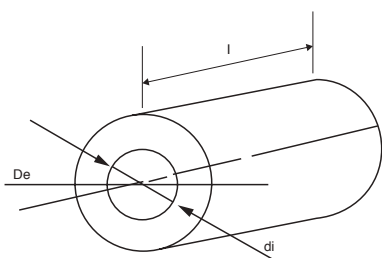

We can produce all diametrical sizes between a minimum bore of 80 mm and a maximum outer diameter of 160 mm.

Suspension via secured chains

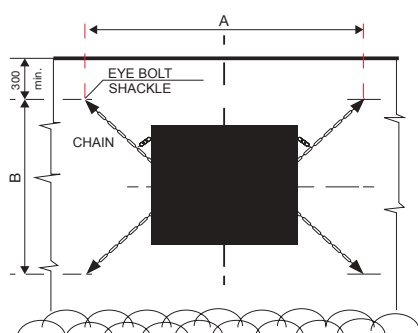

Suspension via tube and eye bolts

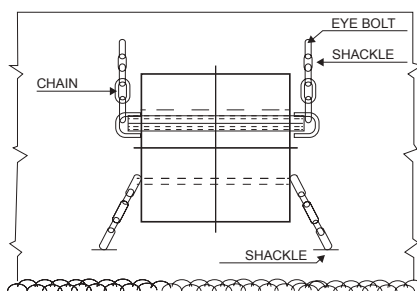

Suspension via tube with cleats

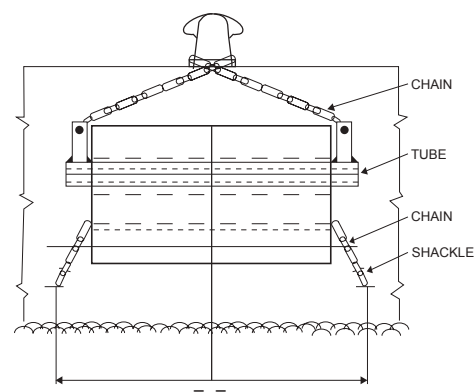

EXTRUDED PROFILES, BUMPERS AND FOAM



Profiles

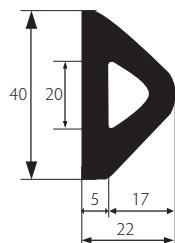

V4PD040
SECTION 40X22
kg/m 0,7 ca.

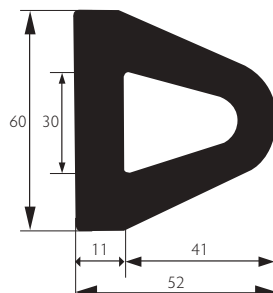

V4PD060
SECTION 60X52
kg/m 2 ca.

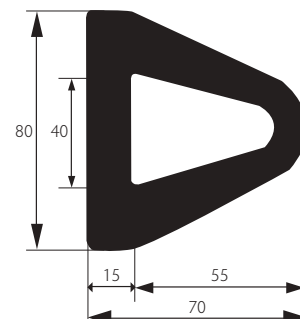

V4PD080
SECTION 80X70
kg/m 4 ca.

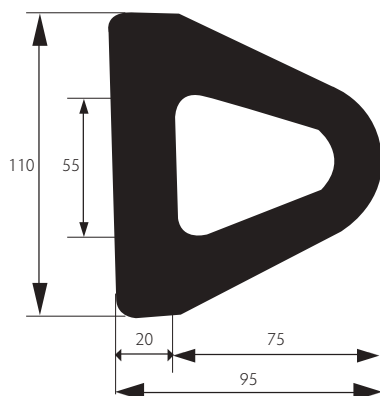

V4PD110
SECTION 110X95
kg/m 7 ca.

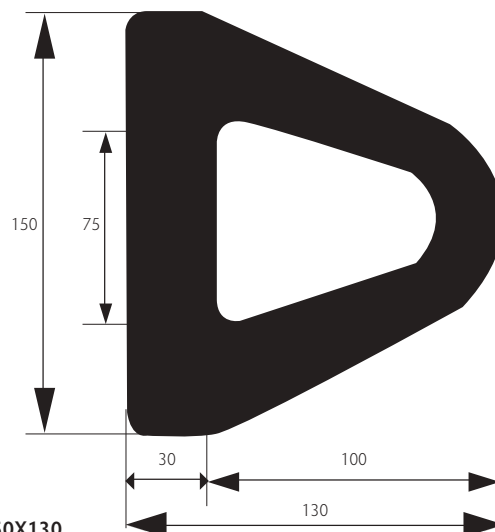

V4PD150
SECTION 150X130
kg/m 14 ca.

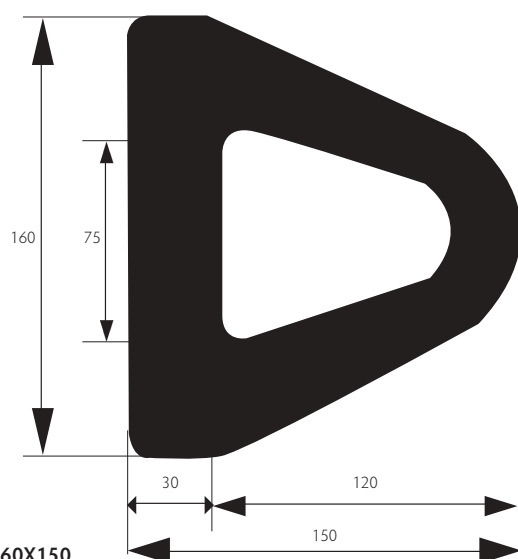

V4PD151
SECTION 160X150
kg/m 15,5 ca.

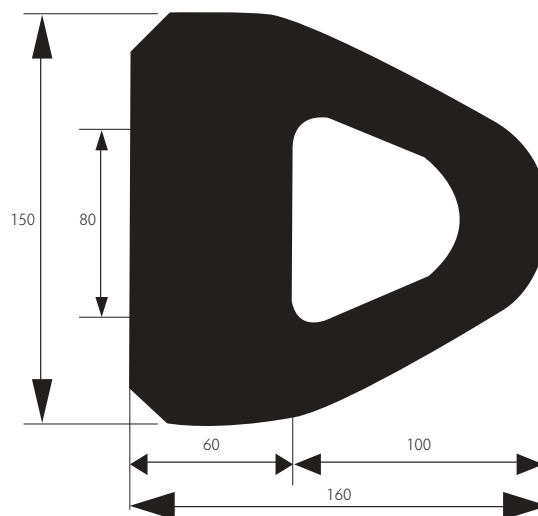

V4PD151K
SECTION 150X160 (on demand with rounded edge)
kg/m 17 ca.

EXTRUDED PROFILES, BUMPERS AND FOAM



Foam

Normal Sponge Rubber - Bright Grey

Characteristics	Note
Polymer: SBR	
Colour: Bright Grey	
Density : 0.6 - 0.7 g/cm ³	The density can vary as a function of the dimensions of the finished product due to the production process.
Flame Resistance: not resistant	
Dilute acids resistance: good	
Base resistance: good	
Ozone resistance: meagre	
Maximum working temperature: 70°C	
Water absorption after 3 days immersion: 5%	

Neoprene Sponge Rubber - Dark Grey

Characteristics	Note
Polymer: Neoprene / SBR	
Colour: Dark Grey	
Density : 0.65 - 0.80 g/cm ³	The density can vary as a function of the dimensions of the finished product due to the production process.
Flame Resistance: wak	
Dilute acids resistance: good	
Base resistance: good	
Ozone resistance: good	
Maximum working temperature: 90°C	
Water absorption after 3 days immersion: 4%	

EPDM Mousse

Characteristics	Note
Polymer: EPDM	
Colour: Black	
Density: 120 +/-20 kg/m ³	Good mechanical resistance and to atmospheric agents.
Flame Resistance (UL94): catches fire	
Ozone resistance: reasonable	
Continuous working temperature: -40°C to 80°C	
Maximum intermittent temperature: 105°C	
Water absorption (ASTM D1056): =<5%	

Neoprene Mousse

Characteristics	Note
Polymer: CR/NBR	
Colour: Black	
Density: 150 +/- 25 kg/m ³	Good weather, flame and oil and chemical product resistance.
Flame Resistance (UL94): SP ≥ 2 mm HF1/SP ≥ 10 mm VØ	
Ozone resistance: good	
Continuous working temperature: -40°C to 100°C	
Maximum intermittent temperature: 115°C	
Water absorption (ASTM D1056): =<5%	

Peroxide / Platinum Cored Silicone Foam

Characteristics	Note
Polymer: VMQ	
Colour: White	
Density : 0,5 g/cm ³	Good mechanical and atmospheric agent resistance. FDA certificate for platinum cured version.
Alongation at brake: 370%	
Compression set: ca.20%	
Continuous working temperature: -50°C to 200°C	
Maximum intermittent temperature: 220°C	
Water absorption (ASTM D1056): =< 5%	

Socaprene

Characteristics	Note
Polymer: CR	
Colour: Black	
Density : 0.15 - 0.20 g/cm ³	Good weather, flame and oil and chemical product resistance. CFC free (2000/53/CE).
Flame Resistance (UL94): 94HF1	
Ozone resistance: very good	
Continuous working temperature: -40°C to 115°C	
Maximum intermittent temperature: 130°C	
Water absorption (ASTM D1056): =<5%	

Softseals

Characteristics	Note
Polymer: PTFE 100%	
Colour: White	
Density: 0,55 g/cm ³	Good weather, oil and chemical product resistance.
Pressure: 210 bar	
Chemical: PH 0-14	
Continuous working temperature: -200°C +280°C	
Maximum intermittent temperature: 315°C	
FDA and WRC norms respected	

Polyurethane Foam

Characteristics	Note
Polymer: PU	
Colour: black, black/yellow	Special profiles for environmental protection of edges and corners. Also used as a bumper or stopper. Good mechanical properties.
Density: 0,30 g/cm ³	
Available in range of temperature : -40°C - +100°C	
Self adhesive	
Smooth surface	
Surface on air with yellow/black stripes for immediate detection of danger.	

EXTRUDED PROFILES, BUMPERS AND FOAM



Foam

FOAM RUBBER SHEETS – RECTANGULAR SECTIONS – NEOPRENE & NORMAL – NON-ADHESIVE SKINS

Section (mm)	Dark Grey NEOPRENE	Available Ex-stock ○ = NO ● = YES	Light Grey NEOPRENE	Available Ex-stock ○ = NO ● = YES
3X10	A richiesta	○	P4SN0310	○
3X15	P4SC0315	○	P4SN0315	●
3X20	P4SC0320	○	P4SN0320	○
3X25	P4SC0325	○	P4SN0325	●
3X30	P4SC0330	○	P4SN0330	○
3X35	P4SC0335	○	P4SN0335	○
3X40	P4SC0340	○	P4SN0340	○
3X50	P4SC0350	○	P4SN0350	○
3X60	P4SC0360	○	A richiesta	○
4X20	A richiesta	○	P4SN0420	○
4X50	A richiesta	○	P4SN0450	●
5X5	P4SC0505	○	P4SN0505	○
5X10	P4SC0510	●	P4SN0510	●
5X12	P4SC0512	○	A richiesta	○
5X15	P4SC0515	●	P4SN0515	●
5X20	P4SC0520	●	P4SN0520	●
5X25	P4SC0525	●	P4SN0525	●
5X30	P4SC0530	○	P4SN0530	●
5X35	P4SC0535	●	P4SN0535	●
5X40	P4SC0540	●	P4SN540	●
5X50	P4SC0550	●	P4SN0550	●
6X6	P4SC0606	○	A richiesta	○
6X10	P4SC0610	○	A richiesta	○
6X20	P4SC0620	●	A richiesta	○
6X30	P4SC0630	○	A richiesta	○
6X35	P4SC0635	○	A richiesta	○
7X50	A richiesta	○	P4SN0750	●
8X8	P4SC0808	○	P4SN0808	●
8X10	A richiesta	○	P4SN0810	●
8X12	A richiesta	○	P4SN0812	●
8X15	P4SC0815	●	P4SN0815	●
8X20	P4SC0820	●	P4SN0820	●
8X25	P4SC0825	●	P4SN0825	●
8X30	P4SC0830	●	P4SN0830	●
8X35	P4SC0835	○	P4SN0835	●
8X40	P4SC0840	●	P4SN0840	●
8X50	P4SC0850	○	P4SN0850	○
10X10	P4SC1010	●	P4SN1010	●
10X12	P4SC1012	●	P4SN1012	●
10X15	P4SC1015	●	P4SN1015	●
10X20	P4SC1020	●	P4SN1020	●
10X25	P4SC1025	●	P4SN1025	●
10X30	P4SC1030	●	P4SN1030	●
10X35	P4SC1035	●	P4SN1035	●
10X40	P4SC1040	○	P4SN1040	●
10X50	P4SC1050	●	P4SN1050	●
10X60	A richiesta	○	P4SN1060	○
10X70	P4SC1070	○	A richiesta	○
12X12	P4SC1212	●	P4SN1212	●
12X15	P4SC1215	●	P4SN1215	●
12X20	P4SC1220	○	P4SN1220	●

EXTRUDED PROFILES, BUMPERS AND FOAM



Foam

FOAM RUBBER SHEETS – RECTANGULAR SECTIONS – NEOPRENE & NORMAL – NON-ADHESIVE SKINS

Section (mm)	Dark Grey NEOPRENE	Available Ex-stock ○ = NO ● = YES	Light Grey NEOPRENE	Available Ex-stock ○ = NO ● = YES
12X25	P4SC1225	●	P4SN1225	○
12X30	P4SC1230	○	P4SN1230	●
12X35	P4SC1235	○	P4SN1235	●
12X40	P4SC1240	●	P4SN1240	○
12X50	P4SC1250	○	P4SN1250	●
15X15	P4SC1515	●	P4SN1515	●
15X20	P4SC1520	●	P4SN1520	○
15X25	P4SC1525	●	P4SN1525	●
15X30	P4SC1530	●	P4SN1530	●
15X35	P4SC1535	●	P4SN1535	●
15X40	P4SC1540	●	P4SN1540	●
15X50	P4SC1550	○	P4SN1550	○
16X16	A richiesta	○	P4SN1616	○
18X18	P4SC1818	●	A richiesta	○
20X20	P4SC2020	●	P4SN2020	○
20X25	P4SC2025	●	P4SN2025	●
20X30	P4SC2030	●	P4SN2030	●
20X35	P4SC2035	●	P4SN2035	○
20X40	P4SC2040	●	P4SN2040	●
20X50	P4SC2050	●	P4SN2050	●
22X22	P4SC2222	●	P4SN2222	○
25X25	P4SC2525	●	P4SN2525	●
25X30	P4SC2530	●	P4SN2530	●
25X35	P4SC2535	●	P4SN2535	○
25X40	P4SC2540	●	P4SN2540	●
25X45	A richiesta	○	P4SN2545	○
25X50	A richiesta	○	P4SN2550	○
30X30	P4SC3030	○	P4SN3030	●
30X40	A richiesta	○	P4SN3040	●
35X35	P4SC3535	○	P4SN3535	○
35X40	P4SC3540	○	A richiesta	○
40X40	P4SC4040	○	P4SN4040	○

EXTRUDED PROFILES, BUMPERS AND FOAM



Foam

RECTANGULAR SPONGE STRIP – EPDM & NEOPRENE – SELF-ADHESIVE

Section (mm)	EPDM black	Available Ex-stock ○ = NO ● = YES	NEOPRENE black	Available Ex-stock ○ = NO ● = YES
5X2	A richiesta	○	P4CA0502	○
5X3	P4EPA0503	○	A richiesta	○
5X5	P4EPA0505	○	A richiesta	○
6X2	P4EPA0602	○	A richiesta	○
6X3	P4EPA0603	○	A richiesta	○
8X8	P4EPA0808	●	A richiesta	○
10X2	P4EPA1002	○	P4CA1002	●
10X3	P4EPA1003	●	P4CA1003	●
10X4	P4EPA1004	●	P4CA1004	●
10X5	P4EPA1005	●	P4CA1005	●
10X6	P4EPA1006	●	P4CA1006	●
10X8	P4EPA1008	●	P4CA1008	●
10X10	P4EPA1010	●	P4CA1010	●
10X12	P4EPA1012	●	A richiesta	○
12X2	P4EPA1202	●	P4CA1202	●
12X3	P4EPA1203	●	P4CA1203	○
12X4	P4EPA1204	○	P4CA1204	●
12X5	P4EPA1205	●	P4CA1205	○
12X6	P4EPA1206	○	P4CA1206	●
12X8	P4EPA1208	●	P4CA1208	●
12X10	P4EPA1210	●	P4CA1210	●
12X12	P4EPA1212	○	P4CA1212	●
14X8	P4EPA1408	○	A richiesta	○
15X2	P4EPA1502	●	P4CA1502	●
15X3	P4EPA1503	●	P4CA1503	●
15X4	P4EPA1504	●	P4CA1504	○
15X5	P4EPA1505	●	P4CA1505	●
15X6	P4EPA1506	●	P4CA1506	●
15X8	P4EPA1508	○	P4CA1508	●
15X10	P4EPA1510	●	P4CA1510	●
15X12	P4EPA1512	●	P4CA1512	●
15X15	P4EPA1515	●	P4CA1515	●
15X20	P4EPA1520	○	A richiesta	○
17X12	P4EPA1712	○	A richiesta	○
18X2	A richiesta	○	P4CA1802	●
18X3	A richiesta	○	P4CA1803	○
18X4	A richiesta	○	P4CA1804	○
18X5	A richiesta	○	P4CA1805	○
18X6	A richiesta	○	P4CA1806	○
18X8	A richiesta	○	P4CA1808	○
18X10	P4EPA1810	○	P4CA1810	○
18X12	A richiesta	○	P4CA1812	○
18X15	P4EPA1815	○	P4CA1815	○
20X2	P4EPA2002	●	P4CA2002	●
20X3	P4EPA2003	●	P4CA2003	●
20X4	P4EPA2004	●	P4CA2004	●
20X5	P4EPA2005	●	P4CA2005	●
20X6	P4EPA2006	●	P4CA2006	○
20X8	P4EPA2008	●	P4CA2008	●
20X10	P4EPA2010	●	P4CA2010	●
20X12	P4EPA2012	○	P4CA2012	●

EXTRUDED PROFILES, BUMPERS AND FOAM



Foam

RECTANGULAR SPONGE STRIP – EPDM & NEOPRENE – SELF-ADHESIVE

Section (mm)	EPDM black	Available Ex-stock ○ = NO ● = YES	NEOPRENE black	Available Ex-stock ○ = NO ● = YES
20X15	P4EPA2015	●	P4CA2015	●
20X18	P4EPA2018	○	A richiesta	○
20X20	P4EPA2020	●	P4CA2020	●
20X30	P4EPA2030	○	A richiesta	○
20X60	P4EPA2060	○	A richiesta	○
25X2	P4EPA2502	●	P4CA2502	○
25X3	P4EPA2503	●	P4CA2503	●
25X4	P4EPA2504	●	P4CA2504	●
25X5	P4EPA2505	●	P4CA2505	●
25X6	P4EPA2506	●	P4CA2506	●
25X8	P4EPA2508	○	P4CA2508	●
25X10	P4EPA2510	●	P4CA2510	●
25X12	P4EPA2512	●	P4CA2512	●
25X15	P4EPA2515	●	P4CA2515	●
25X20	P4EP2520	●	P4CA2520	●
25X25	P4EPA2525	○	A richiesta	○
29X5	P4EPA2905	○	A richiesta	○
30X2	P4EPA3002	●	P4CA3002	●
30X3	P4EPA3003	●	P4CA3003	●
30X4	P4EPA3004	●	P4CA3004	●
30X5	P4EPA3005	●	P4CA3005	●
30X6	P4EPA3006	●	P4CA3006	●
30X8	P4EPA3008	●	P4CA3008	●
30X10	P4EPA3010	●	P4CA3010	●
30X12	P4EPA3012	●	P4CA3012	●
30X15	P4EPA3015	●	P4CA3015	●
30X20	P4EPA3020	●	P4CA3020	●
30X30	P4EPA3030	●	A richiesta	○
31X5	P4EPA3105	○	A richiesta	○
33X10	A richiesta	○	P4CA3310	○
35X2	P4EPA3502	●	P4CA3502	●
35X3	P4EPA3503	●	P4CA3503	●
35X4	P4EPA3504	○	P4CA3504	●
35X5	P4EPA3505	●	P4CA3505	●
35X6	P4EPA3506	●	P4CA3506	○
35X8	P4EPA3508	○	P4CA3508	○
35X10	P4EPA3510	●	P4CA3510	○
35X12	A richiesta	○	P4CA3512	○
35X15	A richiesta	○	P4CA3515	○
40X2	P4EPA4002	●	P4CA4002	○
40X3	P4EPA4003	●	P4CA4003	●
40X4	P4EPA4004	●	P4CA4004	○
40X5	P4EPA4005	●	P4CA4005	●
40X6	P4EPA4006	○	P4CA4006	●
40X8	P4EPA4008	●	P4CA4008	●
40X10	P4EPA4010	●	P4CA4010	●
40X12	P4EPA4012	●	P4CA4012	○
40X15	P4EPA4015	●	P4CA4015	●
40X20	P4EPA4020	●	A richiesta	○
45X5	P4EPA4505	○	P4CA4505	●
45X10	A richiesta	○	P4CA4510	○

EXTRUDED PROFILES, BUMPERS AND FOAM



Foam

RECTANGULAR SPONGE STRIP – EPDM & NEOPRENE – SELF-ADHESIVE

Section (mm)	EPDM black	Available Ex-stock ○ = NO ● = YES	NEOPRENE black	Available Ex-stock ○ = NO ● = YES
50X2	P4EPA5002	●	P4CA5002	●
50X3	P4EPA5003	●	P4CA5003	○
50X4	P4EPA5004	●	P4CA5004	●
50X5	P4EPA5005	●	P4CA5005	●
50X6	P4EPA5006	●	P4CA5006	●
50X8	P4EPA5008	●	P4CA5008	●
50X10	P4EPA5010	●	P4CA5010	●
50X12	P4EPA5012	○	P4CA5012	●
50X15	P4EPA5015	○	P4CA5015	○
50X20	P4EPA5020	●	P4CA5020	○
60X2	P4EPA6002	○	P4CA6002	●
60X3	P4EPA6003	○	A richiesta	○
60X5	A richiesta	○	P4CA6005	○
60X10	A richiesta	○	P4CA6010	○
60X20	P4EPA6020	○	A richiesta	○
70X10	A richiesta	○	P4CA7010	○
75X5	P4EPA7505	○	A richiesta	○
75X6	P4EPA7506	○	A richiesta	○
80X2	P4EPA8002	●	A richiesta	○
80X4	P4EPA8004	○	A richiesta	○
90X 4	P4EPA9004	●	A richiesta	○
100X4	P4EPA10004	○	A richiesta	○

EXTRUDED PROFILES, BUMPERS AND FOAM



Foam

RECTANGULAR SPONGE STRIP – EPDM & NEOPRENE – NON-ADHESIVE

Section (mm)	EPDM black	Available Ex-stock ○ = NO ● = YES	NEOPRENE black	Available Ex-stock ○ = NO ● = YES
5X8	P4EP0508	○	A richiesta	○
8X8	A richiesta	○	P4CR0808	○
10X2	A richiesta	○	P4CR1002	○
10X3	P4EP1003	○	P4CR1003	○
10X4	A richiesta	○	P4CA1004	○
10X5	A richiesta	○	P4CR1005	○
10X6	P4EP1006	○	P4CR1006	○
10X8	P4EP1008	○	P4CR1008	○
10X10	A richiesta	○	P4CR1010	○
12X2	A richiesta	○	P4CR1202	○
12X3	A richiesta	○	P4CR1203	○
12X4	A richiesta	○	P4CR1204	○
12X5	A richiesta	○	P4CR1205	○
12X6	A richiesta	○	P4CR1206	○
12X8	A richiesta	○	P4CR1208	●
12X10	A richiesta	○	P4CR1210	●
12X12	A richiesta	○	P4CR1212	●
15X2	A richiesta	○	P4CR1502	○
15X3	P4EP1503	●	P4CR1503	●
15X4	A richiesta	○	P4CR1504	●
15X5	A richiesta	○	P4CR1505	●
15X6	P4EP1506	●	P4CR1506	○
15X8	A richiesta	○	P4CR1508	○
15X10	P4EP1510	○	P4CR1510	●
15X12	P4EP1512	○	P4CR1512	○
15X15	P4EP1515	●	P4CR1515	●
18X2	A richiesta	○	P4CR1802	○
18X3	A richiesta	○	P4CR1803	○
18X4	P4EP1804	●	P4CR1804	○
18X5	P4EP1805	●	P4CR1805	○
18X6	A richiesta	○	P4CR1806	○
18X8	A richiesta	○	P4CR1808	○
18X10	A richiesta	○	P4CR1810	○
18X12	A richiesta	○	P4CR1812	○
18X15	A richiesta	○	P4CR1815	○
20X2	A richiesta	○	P4CR2002	○
20X3	A richiesta	○	P4CR2003	●
20X4	A richiesta	○	P4CR2004	●
20X5	P4EP2005	●	P4CR2004	○
20X6	A richiesta	○	P4CR2006	●
20X8	P4EP2008	●	P4CR2008	●
20X10	P4EP2010	●	P4CR2010	○
20X12	P4EP2012	●	P4CR2012	○
20X15	P4EP2015	○	P4CR2015	●
20X20	P4EP2020	●	P4CR2020	●
23X3	A richiesta	○	P4CR2303	●
25X2	A richiesta	○	P4CR2502	○
25X3	A richiesta	○	P4CR2503	●
25X4	A richiesta	○	P4CR2504	●
25X5	P4EP2505	●	P4CR2505	●
25X6	A richiesta	○	P4CR2506	○

EXTRUDED PROFILES, BUMPERS AND FOAM



Foam

RECTANGULAR SPONGE STRIP – EPDM & NEOPRENE – NON-ADHESIVE

Section (mm)	EPDM black	Available Ex-stock ○ = NO ● = YES	NEOPRENE black	Available Ex-stock ○ = NO ● = YES
25X8	P4EP2508	●	P4CR2508	●
25X10	A richiesta	○	P4CR2510	●
25X12	A richiesta	○	P4CR2512	○
25X15	P4EP2515	○	P4CR2515	●
25X20	A richiesta	○	P4CR2520	●
30X2	A richiesta	○	P4CR3002	○
30X3	A richiesta	○	P4CR3003	●
30X4	P4EP3004	●	P4CR3004	○
30X5	P4EP3005	●	P4CR3005	○
30X6	A richiesta	○	P4CR3006	●
30X8	P4EP3008	○	P4CR3008	○
30X10	P4EP3010	○	P4CR3010	●
30X12	P4EP3012	●	P4CR3012	●
30X15	P4EP3015	●	P4CR3015	●
30X20	P4EP3020	○	A richiesta	○
30X35	P4EP3035	○	A richiesta	○
35X15	A richiesta	○	P4CR3515	○
35X20	A richiesta	○	P4CR3520	○
40X2	A richiesta	○	P4CR4002	●
40X3	A richiesta	○	P4CR4003	●
40X4	A richiesta	○	P4CR4004	○
40X5	P4EP4005	●	P4CR4005	●
40X6	A richiesta	○	P4CR4006	○
40X8	A richiesta	○	P4CR4008	○
40X10	P4EP4010	●	P4CR4010	●
40X12	A richiesta	○	P4CR4012	●
40X15	P4EP4015	○	P4CR4015	○
40X20	A richiesta	○	P4CR4020	○
40X40	P4EP4040	○	A richiesta	○
45X3	A richiesta	○	P4CR453	○
45X10	P4EP4510	●	A richiesta	○
45X20	A richiesta	○	P4CR4520	○
50X2	A richiesta	○	P4CR5002	○
50X3	P4EP5003	●	P4CR5003	○
50X4	A richiesta	○	P4CR5004	○
50X5	P4EP5005	●	P4CR5005	○
50X6	A richiesta	○	P4CR5006	○
50X8	A richiesta	○	P4CR5008	●
50X10	P4EP5010	○	P4CR5010	○
50X12	A richiesta	○	P4CR5012	○
50X15	A richiesta	○	P4CR5015	●
50X35	P4EP5035	○	A richiesta	○
60X3	A richiesta	○	P4CR6003	○
60X10	A richiesta	○	P4CR6010	○
75X6	P4EP7506	○	A richiesta	○
80X8	P4EP8008	○	A richiesta	○
90X15	A richiesta	○	P4CR9015	○

EXTRUDED PROFILES, BUMPERS AND FOAM



Foam

PEROXIDE CURED SILICONE SPONGE – SELF-ADHESIVE & NON-ADHESIVE

Section (mm)	Non-adhesive SILICONE SPONGE	Available Ex-stock ○ = NO ● = YES	Self-adhesive SILICONE SPONGE	Available Ex-stock ○ = NO ● = YES
8X5	P4SS0805	●	On demand	○
8X8	P4SS0808 *	●	On demand	○
10X2	On demand	○	9AP4SSA1002	○
10X6	P4SS1006	●	On demand	○
10X10	P4SS1010	●	On demand	○
10X12	P4SS1012	●	On demand	○
12X8	P4SS1208	●	On demand	○
15X5	P4SS1505	●	9AP4SSA1505	○
15X8	P4SS1508	●	On demand	○
15X10	P4SS1510 *	●	PAP4SSA1510	○
15X12	P4SS1512	●	On demand	○
15X15	P4SS1515	●	On demand	○
17X9	P4SS1709	●	On demand	○
18X10	P4SS1810	●	On demand	○
18X16	P4SS1816 *	●	On demand	○
20X3	P4SS2003B	○	9AP4SSA2003	○
20X4	On demand	○	9AP4SSA2004	○
20X5	P4SS2005	●	9AP4SSA2005	○
20X6	P4SS2006	●	9AP4SSA2006	○
20X8	P4SS2008	●	On demand	○
20X10	P4SS2010	●	On demand	○
20X12	P4SS2012	●	On demand	○
20X15	P4SS2015	●	On demand	○
20X20	P4SS2020	●	On demand	○
22X7	On demand	○	9AP4SSA2207	○
22X22	P4SS2222	●	On demand	○
25X2	On demand	○	9AP4SSA2502	○
25X5	P4SS2505	●	On demand	○
25X8	P4SS2508	●	9AP4SSA2508	○
25X15	P4SS2515	●	On demand	○
25X20	P4SS2520	○	On demand	○
25X25	P4SS2525	●	On demand	○
30X3	P4SS3003	●	9AP4SSA3003 *	○
30X4	On demand	○	9AP4SSA3004	○
30X5	P4SS3005	●	9AP4SSA3005	○
30X6	On demand	○	9AP4SSA3006	○
30X10	P4SS3010	●	9AP4SSA3010	○
30X15	P4SS3015	●	On demand	○
30X25	P4SS3025	●	On demand	○
40X3	On demand	○	9AP4SSA4003	○
40X8	P4SS4008	●	On demand	○
40X10	On demand	○	9AP4SSA4010	○
40X12	P4SS4012	●	On demand	○
40X30	P4SS4030	○	On demand	○
45X03	P4SS4503	○	On demand	○
45X10	P4SS4510	○	On demand	○
50X5	On demand	○	9AP4SSA5005	○
50X6	On demand	○	9AP4SSA5006	○
50X10	On demand	○	9AP4SSA5010	○
60X5	On demand	○	9AP4SSA6005	○
60X6	On demand	○	9AP4SSA6006	○
60X10	On demand	○	9AP4SSA6010	○

* Size also available in red colour.

EXTRUDED PROFILES, BUMPERS AND FOAM



Foam

NON-ADHESIVE ROD

Diameter (mm)	PEROXIDE cured SILICONE sponge	Available Ex-stock ○=NO ●=YES	NEOPRENE SPONGE Grey	Available Ex-stock ○=NO ●=YES	NORMAL SPONGE Grey	Available Ex-stock ○=NO ●=YES	SOCAPRENE black	Reel Length (m)	Available Ex-stock ○=NO ●=YES
2,5	N.F.	○	N.F.	○	N.F.	○	O4SP0025	1500	○
3	O4SS003	●	N.F.	○	N.F.	○	O4SP003	750	●
3,5	N.F.	○	N.F.	○	N.F.	○	O4SP0035	1500	●
4	N.F.	○	N.F.	○	N.F.	○	O4SP004	1000	●
5	O4SS005	●	O4SC005	○	O4SN005	●	O4SP005	750	●
5,5	N.F.	○	N.F.	○	N.F.	○	O4SP0055	500	●
6	O4SS006	●	O4SC006	○	O4SN006	●	O4SP006	500	●
7	N.F.	○	N.F.	○	N.F.	○	O4SP007	450	●
8	O4SS008	●	O4SC008	●	O4SN008	●	O4SP008	300	●
9	N.F.	○	N.F.	○	N.F.	○	O4SP009	250	●
10	O4SS010	●	O4SC010	○	O4SN010	●	O4SP010	200	●
11	N.F.	○	N.F.	○	N.F.	○	O4SP011	150	○
12	O4SS012	●	O4SC012	○	O4SN012	●	O4SP012	50	●
14	N.F.	○	O4SC014	○	O4SN014	●	O4SP014	50	●
15	O4SS015	●	N.F.	○	N.F.	○	O4SP015	50	●
16	N.F.	○	O4SC016	○	O4SN016	●	O4SP016	50	●
18	N.F.	○	O4SC018	○	O4SN018	●	O4SP018	25	●
19	N.F.	○	N.F.	○	N.F.	○	O4SP019	25	○
20	O4SS020	●	O4SC020	○	O4SN020	●	O4SP020	25	●
22	N.F.	○	O4SC022	○	O4SN022	●	N.F.	-	○
25	N.F.	○	O4SC025	○	O4SN025	●	O4SP025	25	●
30	N.F.	○	O4SC030	○	O4SN030	●	N.F.	-	○
35	N.F.	○	N.F.	○	O4SN035	●	N.F.	-	○

N.F. = Not Available

EXTRUDED PROFILES, BUMPERS AND FOAM



Foam

PTFE SOFTSEALS – NON-SINTERED – RECTANGULAR SECTIONS - WHITE

Code	Dimensions (mm)	Length (m)	Available Ex-stock ○ = NO ● = YES
10PTFENS052	5x2	25	●
10PTFENS0725	7x2,5	25	●
10PTFENS103	10x3	10	●
10PTFENS105	10x5	10	●
10PTFENS124	12x4	10	●
10PTFENS145	14x5	10	●
10PTFENS176	17x6	10	●
10PTFENS207	20x7	5	●
10PTFENS2510	25x10	10	●
10PTFENS3010	30x10	5	●
10PTFENS403	40x3	5	●
10PTFENS405	40x5	10	●

PTFE SOFTSEALS – NON-SINTERED – ROUND SECTIONS - WHITE

Code	Diameter (mm)	Length (m)	Available Ex-stock ○ = NO ● = YES
10PTFETS04	4	50	●
10PTFETS05	5	25	●
10PTFETS06	6	25	●
10PTFETS07	7	25	●
10PTFETS12	12	10	●

SPONGE RUBBER – NORMAL – SKIN – GREY CLEAR – SPECIAL PROFILES

Code	Description	Dimensions (mm)	Available Ex-stock ○ = NO ● = YES
O4SNS12	semi-round NORMAL sponge	D.12 X H.6	●
O4SNS15	semi-round NORMAL sponge	D.15 X H.10	○
O4SNS16	semi-round NORMAL sponge	D.16 X H.8	○
O4SNS20	semi-round NORMAL sponge	D.20 X H.10	○
O4SNS25	Semi-round lengthened NORMAL sponge	SPL12 H.15 L25	○

Other base/height ratios are achievable on customer request

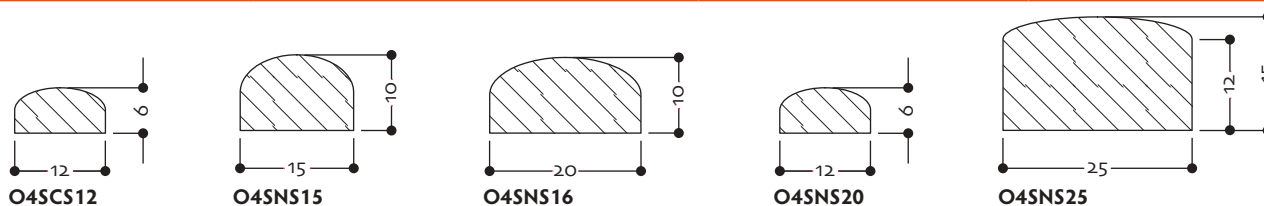

SPONGE RUBBER – NEOPRENE – WITH FILM – DARK GREY – SPECIAL SECTIONS

Code	Description	Dimensions (mm)	Available Ex-stock ○ = NO ● = YES
O4SCS08	semi-round NEOPRENE sponge	D.8 X H.10	○
O4SCS12	semi-round NEOPRENE sponge	D.12 X H.10	○
O4SCS25	Semi-round lengthened NEOPRENE sponge	D.12 X H.10	○

Other base/height ratios are achievable on customer request

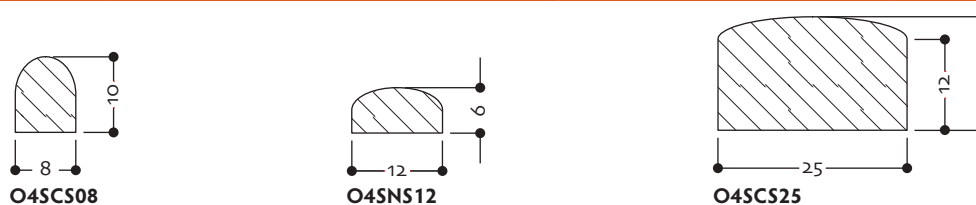

EXTRUDED PROFILES, BUMPERS AND FOAM



Foam

PU FOAM – SELF-ADHESIVE – BLACK/YELLOW** - SPECIAL SECTIONS

Code	Description	Dimensions (mm)	Available Ex-stock ○ = NO ● = YES
P4SPU10967A	PROF.PU ESP.N/G 40X25 L.1500 R10967"A	10967"A	●
P4SPU10969B	PROF.PU ESP.N/G 40X20X8 L.1500 R10969"B"	10969"B"	●
P4SPU10972C	PROF.PU ESP.N/G 40X32 L.1500 R10972"C"	10972"C"	●
P4SPU21214	Triple Angle Black PU Foam R.21214 self-adhesive	21214	●
P4SPU21215	Double Angle Black PU Foam R.21215 self-adhesive	21215	●

** Alternate external black and yellow stripes to indicate danger

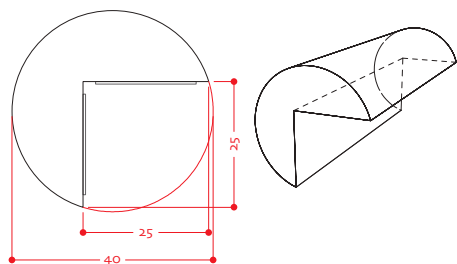

P4SPU10967A

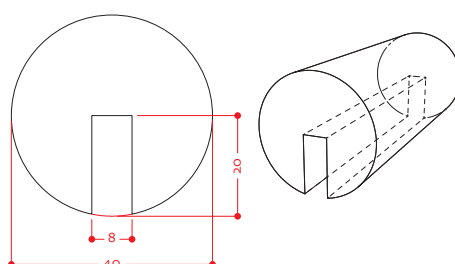

P4SPU10969B

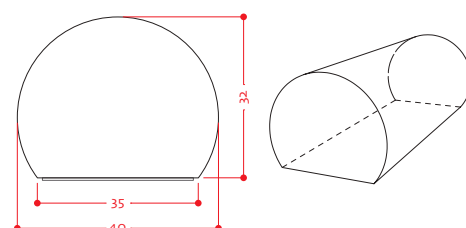

P4SPU10972C

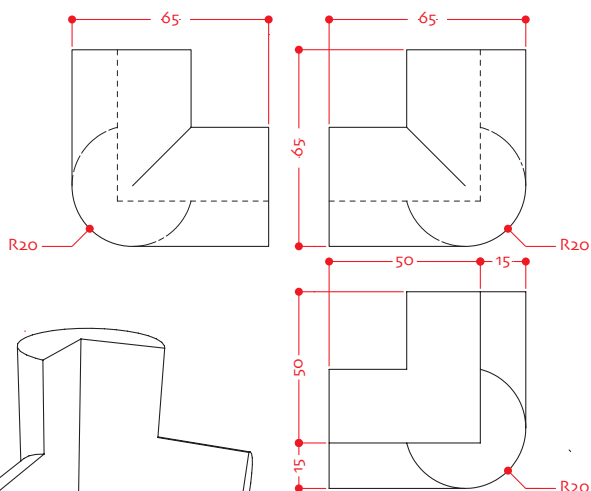

P4SPU21214

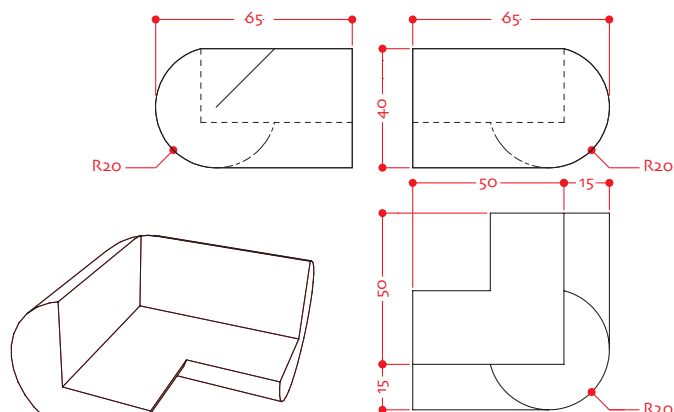

P4SPU21215

ATAG

SERVING INDUSTRY SINCE 1947

IT_20128 MILANO

ph. +39 02 255.22.51
mob. +39 329 68.78.260
ufftec@atag-europe.com

UK_G66 GLASGOW

ph. +44 01360 311.685
mob. +44 0756 204.70.05
andrew.wood@atag-europe.com

CH_SVIZZERA

RTS Group
ph. +41 091 960.04.63
infosvizzera@atag-europe.com

WWW.ATAG-EUROPE.COM

