



FILCOFLEX

SPECIALIST FOR ALL

FLEXIBLE SOLUTIONS

ATAG

SERVING INDUSTRY SINCE 1947

We're originated from Euromanchetten & Compensatoren B.V. in the Netherlands, which is founded in 1981, Filcoflex B.V. was founded in 2008. The name originally means Filtration Compensation and Flexible Solutions. Both companies are managed by 1 family, being a family business since 2004.

WHAT DO WE DO?

We manufacture and design Flexible Connections for Food-, Feed-, Pharmaceutical industries, or any other type of solids-, powder- or pellet-handling, transport and conveying systems such as a; sifter, sieve, fluidbed, bin activator, vibrating gutter, screw conveyor, or pneumatic transport.

This Includes weighing and dosing application for packaging and bulk handling, silo storage, and filling and emptying stations.

WHERE CAN YOU FIND US?

We are represented by a number of resellers and distributors all over the world, please contact us and we will gladly connect you to the right partner. We also answer your questions directly and or help you purchase through our dealer network. Central point is the customer and providing the best and most efficient service to them.

WHAT CAN YOU EXPECT FROM US

- Custom made products to customer requirements in single quantities with a short leadtime
- Speedy production, most products can be produced within a day in case of emergency
- Standard lead-time 1 to 2 weeks
- High quality, certified materials and recognized testing laboratories
- Traceable parts and materials for every product ensuring high quality and quality consistency
- Product configurations and recommendations through our long history and vast experience

Filcoflex Designs their products to be compliant to international standards and regulations, such as:



FLEXIBLE CONNECTIONS

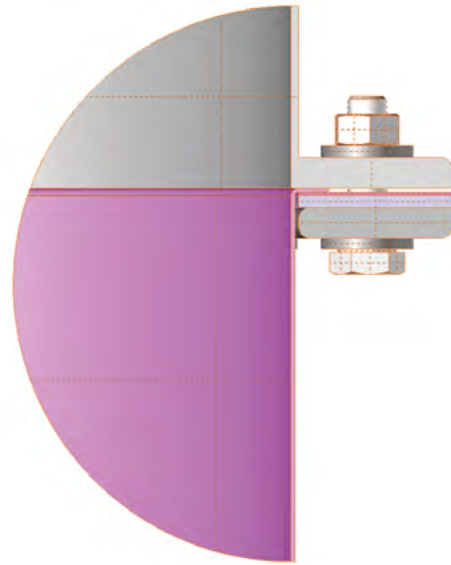

Flange fitted

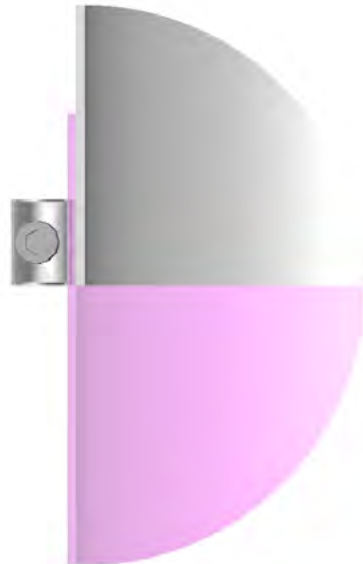

Hoseclamp fitted



JACOB FLEXIBLE CONNECTIONS



FSC

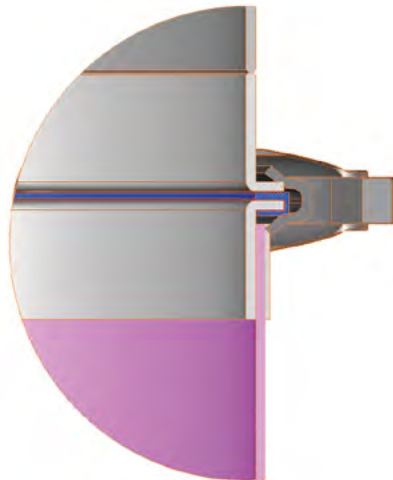

FDM

TRICLAMP FLEXIBLE CONNECTIONS

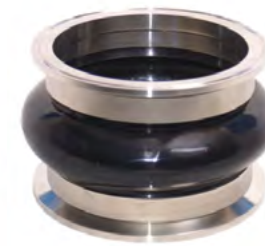
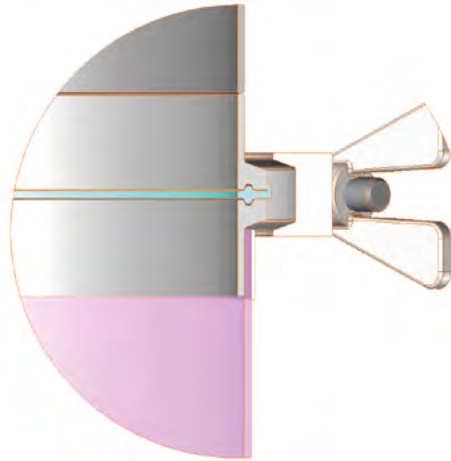

LFR

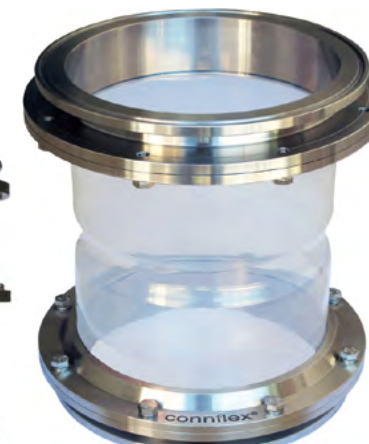
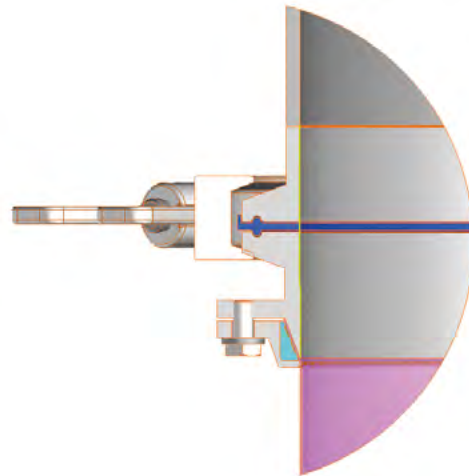

CFL

TRICLAMP FLEXIBLE CONNECTIONS

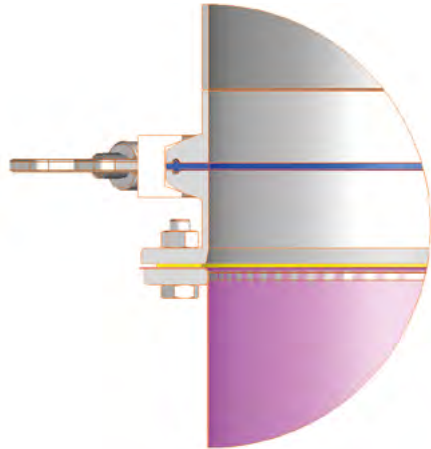

LFDDC

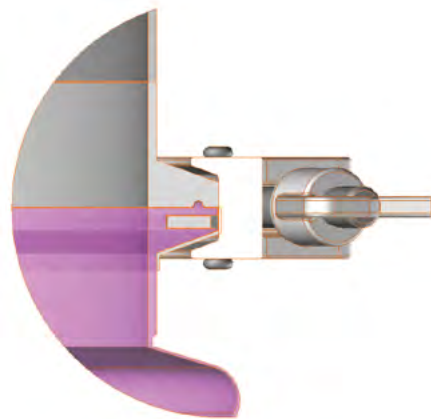

HECHT TRICLAMP

WEIGHING FLEXIBLE CONNECTIONS

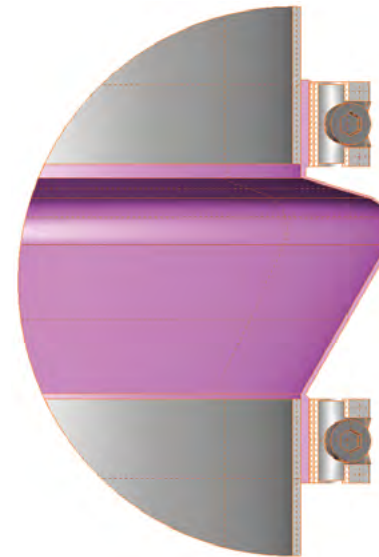

Asymmetrical
Hygienic weighing bellows

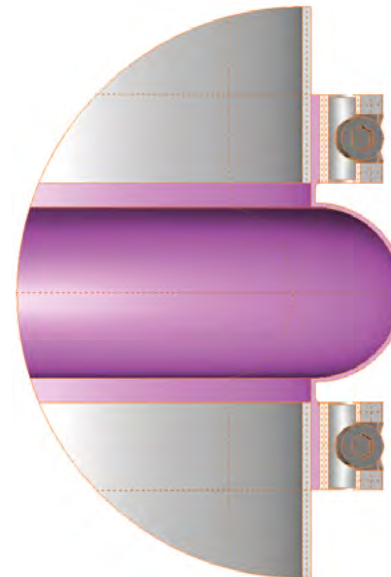

Conductive silicone weighing bellows



WEIGHING FLEXIBLE CONNECTIONS

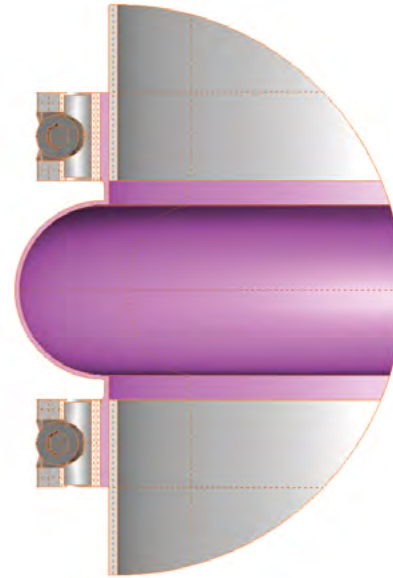

Silicone Weighing Bellows

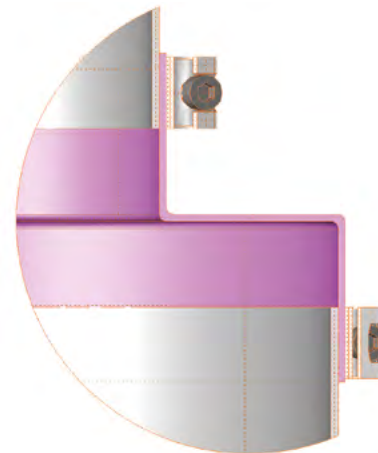

Step Bellows



HOSES

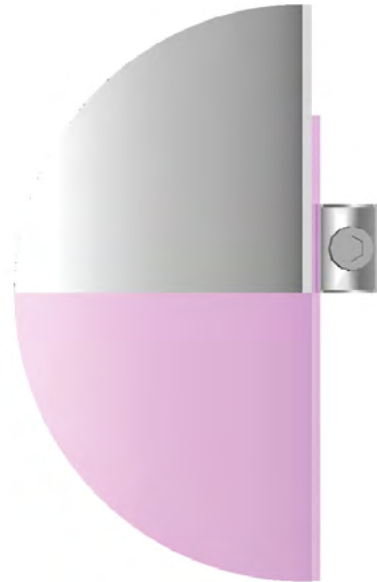

Poly Urethane hose on roll

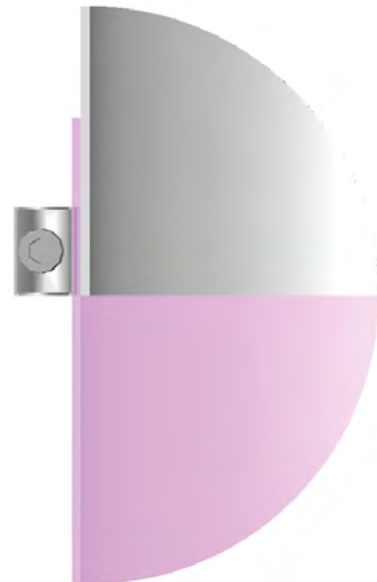

Seamless Silicone hose on roll



INNOVATIVE SEALS



Inflatable bag clamp 1



Pipe tite



INNOVATIVE SEALS



Spray Shields



WE CAN PRODUCE ANY SHAPE
POSSIBLE, HERE ARE SOME EXAMPLES:

- Round
- Rectangular
- Oval
- Round to rectangular or oval adapters
- Angled or offset sleeves
- Conical sleeves
- Sleeves with more than 2 connections,
side
branches, Y splitters
- Reinforcement rings
- Earthing / grounding solutions
- Metal detectable solutions
- Health and safety solutions

Are you in need of an another sollution?
Contact us on info@filcoflex.com. Together we will
come up with the best fitting product for your need.

OUR MAIN PRODUCTS ARE:

- Custom made flexible connections
with any type of coupling
- Flange Fitted
- Hose clamp Fitted
- Triclamp coupling
- Jacob coupling
- Ducting Flange fitted
- Weighing Flexible connections
- Silicone weighing bellows
- Custom made weighing flexible
connections with all sorts of couplings
- Triclamp weighing connections
- Step bellows
- Innovative Seals
- Inflatable Bag clamps
- Wall enclosure seals, covers
- Spray Shields
- Pipe Tite
- Accessories, hose clamps, flanges, etc.



WWW.FILCOFLEX.COM

In collaboratio with

ATAG

SERVING INDUSTRY SINCE 1947

WWW.ATAG-EUROPE.COM

IT_20128 MILANO

ph. +39 02 255.22.51

mob. +39 329 68.78.260

ufftec@atag-europe.com